

Automated Defensive Softball Machine

by

TIMOTHY NOEL

Submitted to the
MECHANICAL ENGINEERING TECHNOLOGY DEPARTMENT
In Partial Fulfillment of the
Requirements for the
Degree of

Bachelor of Science
In
MECHANICAL ENGINEERING TECHNOLOGY

at the

OMI College of Applied Science
University of Cincinnati
May 2004

©.....Timothy Noel

The author hereby grants to the Mechanical Engineering Technology Department permission to reproduce and distribute copies of the thesis document in whole or in part.

Signature of Author

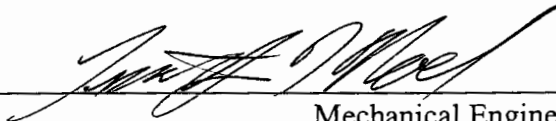

Mechanical Engineering Technology

Certified by

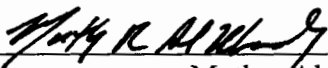

Muthar Al-Ubaidi, PhD,
Thesis Advisor

Accepted by



Dr. Muthar Al-Ubaidi, Department Head
Mechanical Engineering Technology

Abstract

While practice machines have come a long way, the market still offers nothing that will allow an individual player to sharpen their defensive skills. The 11th Man is the first product to offer fully automated motion, gravity fed helical hopper, variable speed release mechanism, and a flexible directional chute. These features allow for full range defensive practice from popup to grounder and first to third base.

A survey was conducted to determine whether this application would be accepted by sports enthusiasts. Both current and retired players were surveyed. The survey supplied information used to create the house of quality. Results determined that the motion and the automatic feeder were the most important customer requirements.

This report covers in depth survey results, research, design, build and testing. Testing of the 11th Man met all the customer requirements. The motion was linkage driven, therefore eliminating costly electrical components, and making it more robust. A helical hopper was designed to insure no jamming while in operation.

Table of Contents

Introduction.....	1
Problem Statement.....	1
Scope of Product.....	2
Customer Perspective of the Problem.....	2
Customer Needs & Prototype Objectives.....	4
Customer Needs.....	4
Prototype Objectives.....	4
Design Solution.....	5
Prototype Fabrication.....	8
Material & Component Availability.....	8
Assembly.....	8
Testing.....	8
Conclusion.....	11
Recommendations.....	12
References.....	13
Appendices.....	A1
Appendix A – General References.....	A1
Appendix B – QFD.....	A2
Appendix C – Calculations.....	A5
Appendix – D- Statement of Financial Support.....	A10
Appendix – E – Proof of Design.....	A12
Appendix – F – Drawings & 3D Models.....	A13

Table of Figures

Figure 1.....	6
Figure A 1-Competitor Comparison.....	A1
Figure A 2-Field Regions.....	A1
Figure A 3-Customer Needs.....	A3
Figure A 4-Survey Results.....	A3
Figure A 5-House of Quality.....	A4
Figure A 6-Weighted Objective.....	A4
Figure A 11-Budget.....	A10
Figure A 12-Schedule.....	A11

Introduction

Problem Statement

Softball enthusiasts have no way to go out to the field and practice defensively by themselves. No machines on the market today can automatically throw softballs to different positions on the field. Machines can throw pop flies, grounders, and pitch. However, you need a minimum of two people in order to practice. These machines are not designed to throw a softball into the outfield or move by themselves. Buying a machine on the market requires a person to manually feed the balls into the machine. The person loading the balls would also have to reposition the machine manually for defensive practice. Therefore, it would not be cost effective to buy a machine and try to use it for defensive practice. The Machine is easily replaced by a friend hitting the balls to you.

Scope of Product

The 11th Man is designed to be the extra player needed to practice by yourself or as a team. It can represent a batter at home plate, or a pitcher on the mound. The design also gives the user continuous practice. Two significant problems need to be solved to make The 11th Man possible. The first problem was making a machine that has the ability to hit balls in a range from foul line to foul line, and pop-fly to grounder. The second problem was to determine how to feed balls automatically. Ball feeding was a challenge since balls had to feed a moving machine. Ball feeding had to be variable since the release time between hitting and fielding is different.

The 11th Man's success is dependent on several variables. The 11th Man must be able to throw a ball into the out field. Its motion must cover foul line to foul line, and pop-up to grounder. The ball feeder must have a minimum capacity of 30 balls to insure continuous practice. The 11th Man must be able to run off standard 110v AC power, and be guarded for safety.

Customer Perspective of the Problem

The 11th Man can be a great addition for a high school or college softball team. It allows the team to have the variety of practice that represents real game situations. This practice removes the coach from behind the plate and puts the coach in the field with the players. This type of coaching should allow for better development of the player. The 11th man also increases the amount of hit balls to each player. During a typical 1 hour practice

players would probably get 20-30 balls hit to him/her in the field. The 11th Man can deliver 10 times that amount.

There are approximately 687 high schools in Ohio [4] and 17175 High schools in the United States [1]. On the college level there are 907 [5] women's softball teams and 864 men's baseball teams in the United States. There are also 30 [6] professional baseball teams and 161 minor league teams. These are all potential users of The 11th Man and this roughly equals 36,216. These numbers do not include the number of organized softball teams both men and women that play throughout the summer.

A spreadsheet (Figure A 1-Competitor Comparison) shows all of the available machines on the market. Seen in Figure A 1-Competitor Comparison there are a total of 11 [2, 3, 7, 8, 9] machines that are closely related to The 11th Man. Jugs and ATEC are the only two manufactures of these machines on the market.

The 11th Man has two major components, the automatic motion and the ball feeding mechanism. When assembled The 11th Man is mounted to a frame and pulled by hand or with a small vehicle. The overall footprint is roughly 4'W x 6'L x 7'H, Eric's portion of this project consisted of a footprint of 2'W x 4'L x 7'H which is mounted to the frame, and my portion consists of a footprint of 4'W x 6'L x 2'H.

The 11th Man is a fully working prototype machine. Meaning all of the desired motions, pitching, infield, outfield, whole team, and single position practice situations. The 11th Man cannot throw trick pitches. Meaning it will not throw a curve ball, knuckle, slider, or sinker. The reason is due to the single wheel design. It takes two wheels to throw the trick pitches.

Customer Needs & Prototype Objectives

Customer Needs

In order to validate the need for the 11th Man, a survey of ball players was conducted. The primary objective of the survey was to determine what features players would like to see in a practice machine.

The results from the survey indicated several things. First, the majority of players responded that the motion both horizontal and vertical were the most important features. Secondly, the ability to control the speed of the thrower to vary ball speeds for different skill levels and practice situations. Lastly, the ball feeder was important to allow for continuous practice. Survey results can be seen in appendix B.

Prototype Objectives

The purpose of building a fully functional prototype is to determine whether the objectives can be met. The objective for my portion of the project is the motion. The motion needs to be capable of covering from foul line to foul line, and pop-up to grounder. This motion also needs to be adaptive for the change over needed to convert from single person to whole team practice. The prototype must also be designed for hours and hours of continuous practice. Due to the continuous nature, a simple yet robust design must be created.

Design Solution

To avoid any confusion, the design was split into two portions. My partner designed the ball feeder and the thrower while the motion was under my control.

Building a successful prototype starts with a successful design. To determine the design, customer surveys were totaled and placed in to the QFD (Quality Functional Deployment). The QFD defines the best solution to a customer need. The motion of The 11th Man is being defined as the horizontal and vertical motion. Horizontal motion allows the machine to move from foul line to foul line. The vertical motion allows the machine to throw ground balls and pop flies.

The first design (Design I) was a motor attached to the whole machine in order to deliver the horizontal motion. There would be moveable switches to stop the motor electrically and to change direction. This design requires a PLC to control the motor when it reaches the switches. A pneumatic cylinder and proximity switches would control the vertical motion. There would also have to be a 3-way pneumatic valve added to change directions on the vertical motion.

Design II removes the electric motor from the horizontal motion and adds an additional cylinder to move the machine. There would also have to be another 3-way pneumatic valve for the horizontal motion. The major issue with the three way valves is that you still need some type of controller like a PLC to control Design II.

Design III is a four bar linkage for both the horizontal and vertical motions. With this design all the switches, valves, and PLC's are eliminated and the machine becomes purely mechanical.

Figure 1 shows a sketch of each of the designs. Designs one and two were created to meet the requirements of the three design proposals. Three designs were needed to perform the Weighted Objective Method. The Weighted Objective Method determined that design III was the best design for the application.

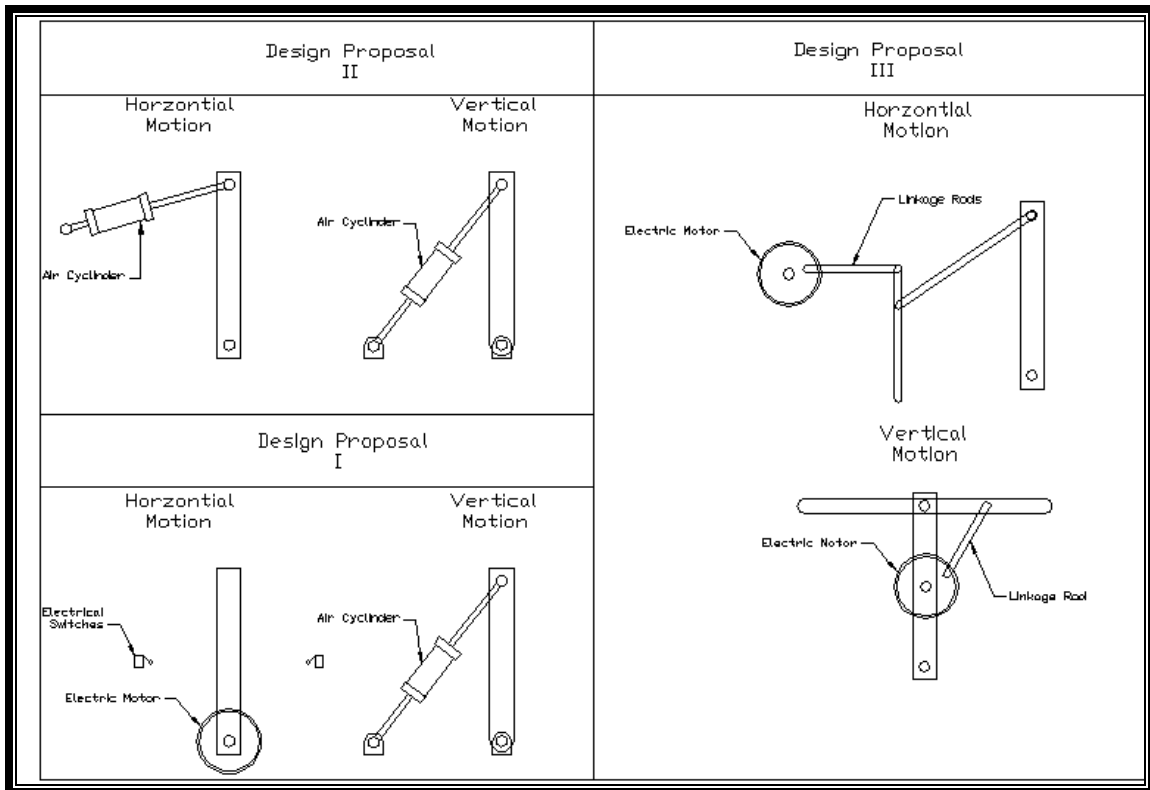

Figure 1

To insure design III would meet the requirements of the customer and the environment a pre-prototype was developed. The pre-prototype was a wooden model that simulated the basic linkage needed to develop the desired motion. There were several iterations built, one had a slot in the link riding on the disk, another had an egg shaped disk to create the motion. This pre-prototyping was the best way to determine how the motion was going to be designed and built. It was an inexpensive means to a solution that would be robust.

After pre-prototyping, the design concept was transferred into SolidEdge version 14. SolidEdge is a solid modeling package, and was chosen because of the animation package available to the students. The animation package further confirmed that the motion designed would properly function. Once confirmed, calculations were performed to determine factor of safeties on each critical component. These calculations can be seen in Appendix C.

Prototype Fabrication

Material & Component Availability

The intent while building the 11th Man was to use low cost materials and components that were readily available or obtainable within 5 working days. Since this project was self-funded and a prototype, this philosophy yielded desirable results at a low cost. Raw materials required for fabrication of the horizontal and vertical motion consisted of standard cold rolled steel. The framework and support system were also built using cold rolled steel. The steel was purchased from a scrap yard. Specialty items needed to construct the motions were bearings, shoulder bolts, 2 variable cam disks, 2 DC gear motors, 2 bridge rectifiers, gearbox, and a variable speed drive. The motors, rectifiers, variable speed drive, and gearbox were located at Mendelson's Liquidation Outlet. The rest of the components were ordered from McMaster-Carr.

Assembly

Assembly methods to build The 11th Man consisted of basic welding, drilling and a few machining of slots or grooves. Assembly Tolerances were plus or minus ¼ inch, except for motor assemblies. The motors had to be assembled parallel to each motion, if not the links would have a tendency to bind or lock up on the cam disks. The tolerance for motor components had to be plus or minus .005. The frame was designed to house both motions and the thrower mechanism. The hopper assembly was welded on to the back of the frame due to the motion and the need for the balls to be gravity fed.

Testing

The 11th Man was tested for durability and accuracy. Testing consisted of throwing a full load of balls while in automatic mode to determine if it reached each of the desired regions (Figure A 2-Field Regions). The test was successful the machine could throw balls in every region desired. Testing also consisted of a dry fire run in full auto mode for 2 hours. During this full auto test the machine was not throwing a ball, it just ran the horizontal and vertical motions. During the 2 hour test, nothing bound up therefore being successful. The last test conducted was to insure users could change machine positions to get the desired form of practice. The change over process means that in order to change from full auto to single position practice the user had to move the links on the cam motion disks to get there desired motion. This is to be accomplished in less than five minutes. During the change over test the process was observed to insure that users could not get hurt. To test the change over positions five women and five men change the machine over from one position to another. During the change-over the testers were timed and at the end, asked if they felt unsafe during the test. They responded that the machine did not pose a threat to them while changing positions. However they did mention that it was more difficult to change the vertical motion to a different position due to the weight of the thrower mechanism. The vertical position change over is more difficult, but still meets the criteria of the design. A solution to this problem will be addressed at a later date.

Also for safety considerations The 11th Man is wrapped in a Mesh guarding to keep users from getting in the machine on accident and also to protect it from any ball being hit at it during batting practice. Also for safety there is a remote control added to allow the user to get into position before the machine begins to throw balls. The remote

allows the user to turn off the ball feeder motor while in the field. There is a light attached to this for visual verification. The 11th Man was built as a fully functional full-size working prototype to perform the above testing procedures.

The dry fire test was run and completed successfully with no issues. The change-over test was successful.

Conclusion

Throughout the design, build and testing of The 11th Man the concept was always thought to be innovative and leading edge technology. The 11th Man did not disappoint in any regards. The testing was 100% successful. All the objectives to throw the ball anywhere and be able to practice with it were successful. The 11th Man provides a complete work out for softball enthusiasts. The machine can pitch, throw grounder anywhere in the infield, and throw balls into the out field in any region. Basically The 11th Man is the ultimate hitter for defensive practice. It is also the ultimate pitcher, it has the variability of a good pitcher. With these feature the users' skills can be honed and formed by The 11th Man.

Recommendations

The 11th Man was the initial prototype therefore as always changes can be made to make it better. One thing that should be changed immediately would be the gearbox on the vertical motion. The gearbox was added since a gear motor with the proper speed and torque could not be found. The motor exists but not purchased due to budget constraints. Other things that could be changed would be the frame and the wiring. The frame could be made out of aluminum rather than steel, this would make the entire assembly lighter and easier to move. The wiring could be incorporated into a single electrical box rather than 2 boxes currently. Also rather than having breakers for switches, real switches with inline fuses could be used to better protect the machine from blowing a motor.

References

1. Athletic Training Equipment Company. <<http://www.atecsports.com>> 2003, October 5.
2. The Jugs Company. <<http://www.thejugscompany.com>> 2003, October 5.
3. Fogdog. <<http://www.fogdog.com>> 2003, October 5.
4. Be a Pro. <<http://www.beapro.com>> 2003, October 5.
5. U.S. Census Bureau. <<http://eire.census.gov/popest/estimates.php>> 2003 October 12
6. Widgets. <<http://www.widgets.ws/prod/SportsAuthority/Team-Sports/Baseball/Training-Aids/Pitching-Machines/>> 2003, October 5.
7. NCAA <<http://www.ncaa.org>> 2003, October 5.
8. Reunion.com <<http://www.reunion.com>> 2003, October 5.
9. Grainger. <<http://www.grainger.com>>2003, October 11
10. Major League Baseball. <<http://mlb.mlb.com>> 2003, October 5.
11. Interactive Four-Bar Linkage Position Analysis. <<http://iel.ucdavis.edu/design/fourbar/>> 2003 ,October 5
12. USPTO Patent Full Text and Image Database. <<http://patft.uspto.gov/netacgi/>> 2003, October 28

Appendices

Appendix A – General References

Figure A 1-Competitor Comparison

Manufacture	Model	Automatic Motion	Variable Speed	Cost	Weight	HP	Balls Type	Transport Wheels	Pop Files	Grounders	Feeder Included	Feeder Compatible	Vertical Pivot	Horizontal Motion	# Of Wheels
ATEC	Hitting Streak	No	No	\$399.99	27	1/4	foam only	No	Yes	Yes	No	No	Yes	Yes	1
Jugs	Toss Machine	No	No	\$349.99	13	0	Any	No	No	No	No	No	No	No	0
Jugs	Super Softball	No	Yes	\$1,899.99	75	1/4	Any Softball	No	Yes	Yes	No	Yes	Yes	Yes	1
Jugs	Combo Baseball/Softball	No	Yes	\$2,499.99	145	1/4	Any	No	Yes	Yes	No	Yes	Yes	Yes	2
ATEC	Casey Pro	No	Yes	\$2,199.99	105	1/4	Any Softball	No	Yes	Yes	No	Yes	Yes	Yes	2
ATEC	Casey	No	Yes	\$1,999.99	115	1/4	Any Softball	No	Yes	Yes	No	Yes	Yes	Yes	2
ATEC	Power Hummer	No	Yes	\$1,799.99	115	1/4	Any Softball	No	Yes	Yes	No	No	Yes	Yes	2
ATEC	Axis	No	Yes	\$1,599.99	65	1/4	Any Softball	No	Yes	Yes	No	No	Yes	Yes	1
Jugs	Jr Combo Baseball/Softball	No	Yes	\$1,399.99	75	1/4	Any	No	Yes	Yes	No	Yes	Yes	Yes	1
ATEC	Rookie	No	Yes	\$1,299.99	65	1/4	Any Softball	No	Yes	Yes	No	Yes	Yes	Yes	2
ATEC	Casey Jr	No	Yes	\$949.99	50	1/4	Any	No	Yes	Yes	No	Yes	Yes	Yes	1
Senior Design	Fullout	Yes	Yes				Any	Yes	Yes	Yes	Yes	Yes	Yes	Yes	1

Figure A 2-Field Regions

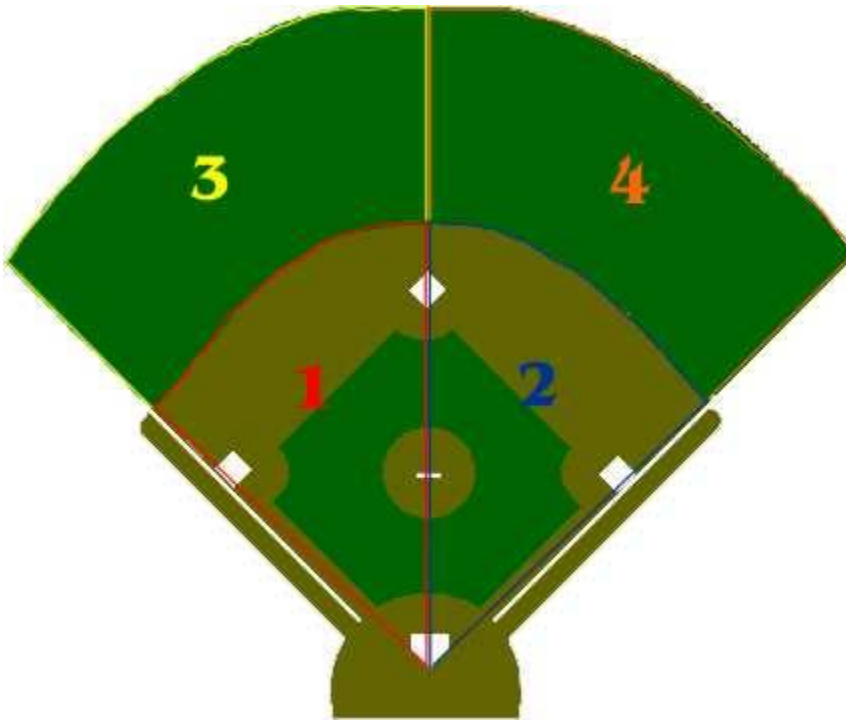

Appendix B – QFD

Baseball/Softball Practice Machine Survey

I am a senior in the Mechanical Engineering program at the University of Cincinnati and I am currently working on my senior design project. The design is for a new practice machine that not only pitches, but gives defensive practice as well. The goal is simulate game time pitches and hits as realistically as possible.

*While ranking this survey 5 is the highest of importance to you

Are you currently an active baseball or softball player?	Yes	No						
Do you or your team currently own a pitching machine?	Yes	No						
If yes:								
Are you happy with it?			1	2	3	4	5	
If no:								
Are you interested in purchasing one?			1	2	3	4	5	
If you were to purchase a pitching machine would you be interested in it to do more than just pitching?	Yes	No						

Please rate each of the following features

Ability to automatically throw balls randomly to the entire field in order to simulate game time hits during practice			1	2	3	4	5
Ability to automatically throw balls randomly to specific regions of the field (i.e. shortstop, left field, first base, etc.) in order to simulate game time hits during practice			1	2	3	4	5
Ability to automatically vary pitches in order to simulate game time pitching practice			1	2	3	4	5
To have an integrated automatic ball feeder that hold up to 50 balls			1	2	3	4	5
Ability to adjust the time in between throws			1	2	3	4	5
Game time velocities			1	2	3	4	5
Weight			1	2	3	4	5
Size			1	2	3	4	5
Cost			1	2	3	4	5
Reliability			1	2	3	4	5
Maintenance			1	2	3	4	5
Safety			1	2	3	4	5

Any other suggestions:

Figure A 3-Customer Needs

Whats	Hows
1 Pop flies to Ground Balls	Vertical Motion
2 From 1st to 3rd base	Horizontal Motion
3 Pitching to fielding practice	Variable speed Thrower
4 Baseballs to softballs	Adjustable ramp plate
5 Single person operation	Automatic ball feeder
6 Size	Design
7 game time velocities	Strong enough motor
8 Cost	Low Cost Materials
9 Reliability	Design and component selection
10 Maintenance	Design for assembly
11 Safety	Remote control

Figure A 4-Survey Results

Survey Results												Average	
1	Currently an active player	0	0	5	0	0	0	0	5	0	5	5	36.36%
2	Own Pitching Machine	0	0	0	0	0	0	0	0	0	0	0	0.00
3	Intrested in Purchasing	3	0	0	5	5	0	0	3	5	5	3	2.64
4	More than just pitching	5	0	0	5	5	0	0	5	5	5	5	3.18
5	Randomly across entire field	5	4	5	5	5	5	4	5	4	4	4	4.55
6	Randomly to specific regions	4	4	5	5	5	5	4	5	4	5	3	4.45
7	Pitch variations	3	5	5	5	4	3	4	5	5	5	5	4.45
8	Automatic ball feeder	5	5	5	5	4	3	4	5	3	3	5	4.27
9	adjust time between throws	4	3	4	5	3	4	4	4	4	3	5	3.91
10	game time velocities	4	5	4	5	5	4	4	4	5	5	5	4.55
11	wieght	3	3	4	5	5	3	3	4	3	1	3	3.36
12	Size	3	3	4	5	5	4	3	3	3	1	3	3.36
13	Cost	5	5	5	5	4	5	4	5	3	5	5	4.64
14	Reliability	5	3	5	5	5	5	4	4	4	4	5	4.45
15	Maintenance	5	5	5	5	5	4	4	4	4	3	4	4.36
16	Safety	5	5	5	5	5	5	4	5	5	2	4	4.55

Figure A 5-House of Quality

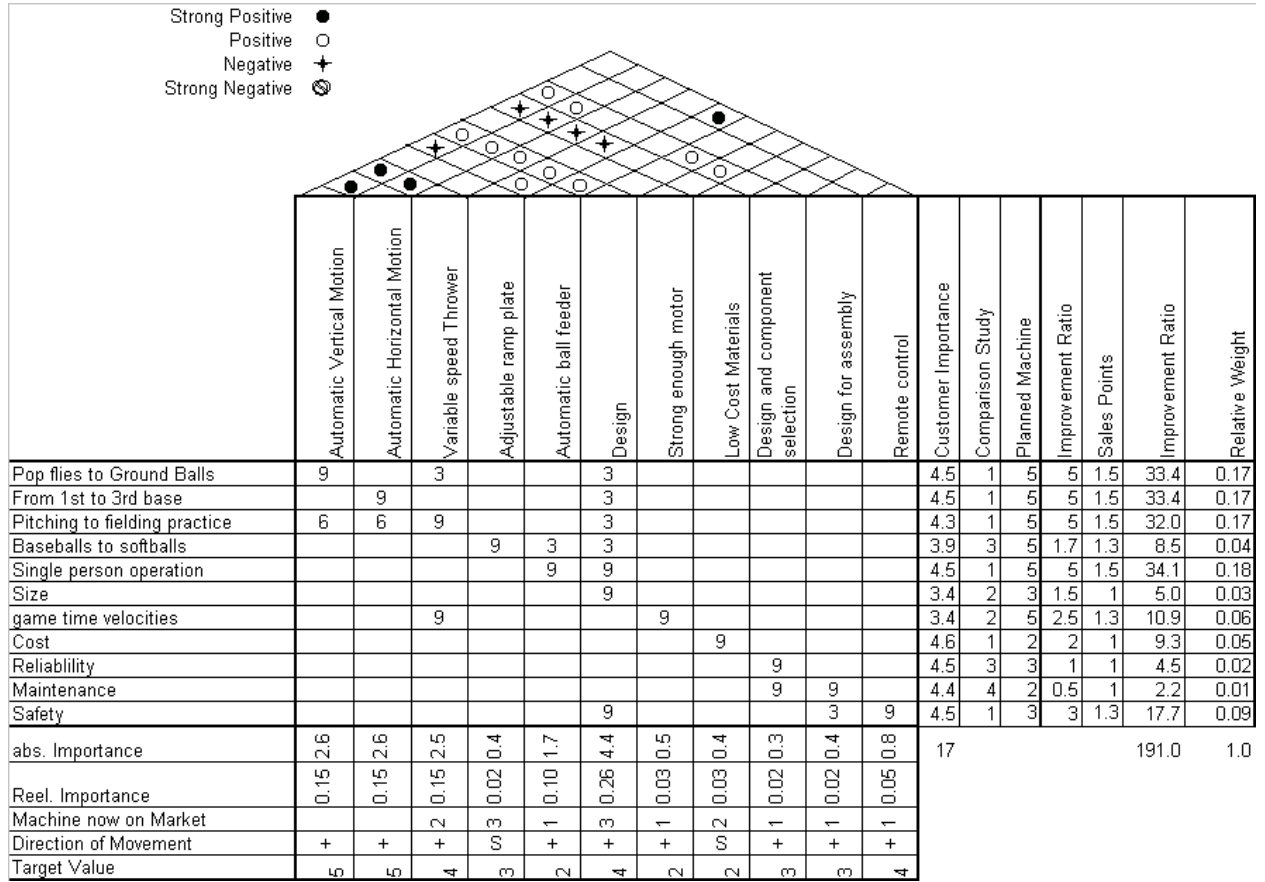

Figure A 6-Weighted Objective

Weighted Objective for Motion

Design Criteria	Weight	Design 1		Design 2		Design 3	
		S	U	S	U	S	U
Automatic Vertical Motion	15	10	1.54	10	1.54	10	1.54
Automatic Horizontal Motion	15	10	1.54	10	1.54	10	1.54
Variable speed Thrower	15	0	0.00	0	0.00	0	0.00
Adjustable ramp plate	2	0	0.00	0	0.00	0	0.00
Automatic ball feeder	10	0	0.00	0	0.00	0	0.00
Design	26	7	1.83	7	1.83	10	2.61
Strong enough motor	3	9	0.27	9	0.27	10	0.30
Low Cost Materials	3	2	0.06	4	0.12	10	0.30
Design and component selection	2	4	0.07	7	0.13	10	0.18
Design for assembly	2	3	0.07	9	0.20	10	0.22
Remote control	5	0	0.00	0	0.00	0	0.00
Overall Utility			5.38		5.62		6.69

Appendix C – Calculations

Item	Calculation		
H1	Horse Power Needed For Horizontal Motion		
	Mass of assy	W	200 lbs
	Coef of Friction	u	0.2
	$f = u * W = \text{Friction Force}$ $f = 40 \text{ lbf}$ $T = fd = \text{Torque on the Horizontal Motor}$ $d = 4 \text{ inches}$ $T = 160 \text{ in - lbs}$ $Hp = T * RPM$ $RPM = 30$ $Hp = 0.076$		
	Safety Factor	=	1.25
	Hp	=	0.095
			Minimum Hp needed for Horizontal Motion
H2	Pin dia - Pins 1 & 2		
	Force	F	40 lbs
	Yield Stress of Material	y	42000 psi
	$F/A = y$ $A = 0.001 \text{ in}^2$ $A = \text{Area} = \text{PI} * d^2 / 4$ $d = 0.035 \text{ in}$		
	Safety Factor	=	4
	d	=	0.139 in
			Minimum Diameter for Pin #1 & Pin #2
H3	Link Buckling - Link 1		
	Modulus of Elasticity	E	11500000 psi
	Length	L	24 in
	Base	b	1 in
	Height	h	0.25 in
	$I = \text{Moment of Inertia}$ $I = (1/12)bh^3$ $I = 0.001 \text{ in}^4$		

Fcr = Buckling Force

$$F_{cr} = (EI \cdot \pi^2) / L^2$$

$$F_{cr} = 256.5747 \text{ lb}$$

Resultant Safety Factor

$$S = F_{cr} / \text{Fact}$$

$$S = 6.41$$

H4 Shaft Diameter - Horizontal

Design Factor	N	2
Torque of Shaft	T	160 in-lbs
Yield Stress of Material	Sy	71000 psi

$\tau_d = \text{Design Stress}$

$$\tau_d = S_y / 2N$$

$$\tau_d = 17750.00 \text{ psi}$$

Zp = Polar Section Modulus

$$Z_p = T / \tau_d$$

$$Z_p = 0.01 \text{ in}^3$$

D = Shaft Diameter

$$D = ((16Z_p) / \pi)^{1/3}$$

$$D = 0.36 \text{ in}$$

H5 Key Stress - Key 1 Seat

Diameter of Shaft	D	0.5 in
Torque of Shaft	T	160 in-lbs
Stress Concentration factor	Kt	2
Yield Stress of Material	Sy	71000 psi

Zp = Polar Section Modulus

$$Z_p = (\pi \cdot D^3) / 16$$

$$Z_p = 0.02 \text{ in}^3$$

$\tau_{nom} = \text{Nominal Stress}$

$$\tau_{nom} = T / Z_p$$

$$\tau_{nom} = 6518.99 \text{ psi}$$

$\tau = \text{Stress in key}$

$$\tau = K_t \cdot \tau_{nom}$$

$$\tau = 13037.97 \text{ psi}$$

Resultant Safety Factor

$$S = S_y / \tau$$

$$S = 5.45$$

H6 Key Stress - Key 1 Width

Yield Stress of Material	Sy	51000 psi
Width of Key	W	0.125 in
Length of Key	L	0.75 in

Shaft Diameter - Horizontal	D	0.5 in
Torque of Shaft	T	160 in-lbs
Assumptions from Machinist Handbook		
$\tau_k = \text{Key Stress}$		
$\tau_k = 2 * T / (WLD)$		
	$\tau_k =$	6826.67 psi
Resultant Safety Factor		
$S = S_y / \tau_k$		
	S =	7.47

V1 Horse Power Needed For Vertical Motion

Weight of Feeder	W1	0 lbs
Weight of Thrower	W2	35 lbs
Dimension	x	10 in
Dimension	y	2 in
Dimension	z	4 in

Sum of the Moments Equation
 $F_m = (W_2 y - W_1 x) / z = \text{Force to the Vertical Motor}$
 $F_m = 17.5 \text{ lbs}$

Mass of assy	Fm	17.5 lbs
coef of Friction	u	0.2

$f = u * F_m = \text{Friction Force}$
 $f = 3.5 \text{ lbf}$

Total Force
 $F_t = F_m + f$

$F_t = 21$
 $T = F_t * d = \text{Torque on the Vertical Motor}$

$d = 4 \text{ inches}$
 $T = 84$

$H_p = T * \text{RPM}$
 $\text{RPM} = 30$
 $H_p = 0.040$

Safety Factor = 1.25

Minimum Hp
needed for
Vertical
Motion

$H_p = 0.050$

V2 Pin dia - Pins 3 & 4

Force	F	21 lbs
Yield Stress of Material	y	42000 psi

$F/A = y$
 $A = 0.001 \text{ in}^2$

	$A = \text{Area} = \text{PI} \cdot d^2 / 4$ $d = 0.025 \text{ in}$ Safety Factor = 4			Minimum Diameter for Pin #3 & Pin #4
	$d = 0.101 \text{ in}$			
V3	Pin dia - Center Pin			
	Weight of Assembly	W	35 lbs	
	Force	F	35 lbs	
	Yield Stress of Material	y	42000 psi	
	$F/A = y$ $A = 0.001 \text{ in}^2$ $A = \text{Area} = \text{PI} \cdot d^2 / 4$ $d = 0.033 \text{ in}$ Safety Factor = 4			Minimum Diameter for Center Pin
	$d = 0.130 \text{ in}$			
V4	Link Buckling - Link 2			
	Modulus of Elasticity	E	11500000 psi	
	Length	L	12 in	
	Base	b	1 in	
	Height	h	0.25 in	
	$I = \text{Moment of Inertia}$ $I = (1/12)bh^3$ $I = 0.001 \text{ in}^4$ $F_{cr} = \text{Buckling Force}$ $F_{cr} = (EI \cdot \text{PI}^2) / L^2$ $F_{cr} = 1026.299 \text{ lb}$ Resultant Safety Factor $S = F_{cr} / \text{Fact}$ $S = 48.87$			
V5	Shaft Diameter - Vertical			
	Design Factor	N	2	
	Torque of Shaft	T	84 in-lbs	
	Yield Stress of Material	Sy	71000 psi	
	$\tau_d = \text{Design Stress}$ $\tau_d = S_y / 2N$ $\tau_d = 17750.00 \text{ psi}$ $Z_p = \text{Polar Section Modulus}$			

		$Z_p = T/\tau d$		
		$Z_p =$	0.00	in ³
		D = Shaft Diameter		
		$D = ((16Z_p)/\pi)^{(1/3)}$		
		D =	0.29	in
H5	Key Stress - Key 1 Seat			
	Diameter of Shaft	D	0.5	in
	Torque of Shaft	T	84	in-lbs
	Stress Concentration factor	Kt	2	
	Yield Stress of Material	Sy	71000	psi
	Zp = Polar Section Modulus			
	$Z_p = (\pi D^3)/16$			
	Zp =		0.02	in ³
	τ_{nom} = Nominal Stress			
	$\tau_{nom} = T/Z_p$			
	$\tau_{nom} =$		3422.47	psi
	τ = Stress in key			
	$\tau = K_t \tau_{nom}$			
	$\tau =$		6844.94	psi
	Resultant Safety Factor			
	$S = S_y/\tau$			
	S =		10.37	
H6	Key Stress - Key 1 Width			
	Yield Stress of Material	Sy	51000	psi
	Width of Key	W	0.125	in
	Length of Key	L	0.75	in
	Shaft Diameter - Horizontal	D	0.5	in
	Torque of Shaft	T	84	in-lbs
	Assumptions from Machinist Handbook			
	τ_k = Key Stress			
	$\tau_k = 2T/(WLD)$			
	$\tau_k =$		3584.00	psi
	Resultant Safety Factor			
	$S = S_y/\tau_k$			
	S =		14.23	

Appendix – D- Statement of Financial Support

In order to build this machine Eric and I have secured \$500.00 donation to put towards the materials. Beyond that point Eric and I will fund the project personally. We plan to build the project in my garage where I have various tools to accomplish this. We will out source or locate a machine shop for any components we cannot build in my garage or use the north lab machine shop. All testing will be done at Eric’s church, which has a softball field; we will be borrowing a generator from Jeremy Holcomb in order to run the machine in the field. When this project is finished Eric will maintain possession of the prototype.

Components	Quantity	Cost	Ext cost	Cash donations	Physical Donations	Eric's	Tim's
Gear motor	2	\$ 225.00	\$ 225.00	1	1 motor already donated		X
Variable speed motor (1/3 hp)	1	\$ 225.00	\$ 225.00			X	
Variable speed drive	2	\$ 95.00	\$ 190.00	1		X	
Variable speed motor (small)	1	\$ 70.00	\$ 70.00	1		X	
Wheels	2	\$ 27.00	\$ 54.00				X
Steel tubing	30ft	\$1 per ft	\$ 30.00				X
Bearings	Unknown	\$ 75.00	\$ 75.00				X
Pins	8	\$ 10.00	\$ 10.00				X
1x.25x? (linkage) flat plate	5	\$1 per ft	\$ 5.00				X
8in dia 1/4 thick round plates	2	\$ 25.00	\$ 50.00				X
Tim's Misc		\$ 100.00	\$ 100.00				X
Steel Tubing	12ft	\$1 per ft	\$ 12.00			X	
Flexible tubing	20ft	\$5 per ft	\$ 100.00			X	
Pillow block bearing	2	\$ 15.00	\$ 30.00		bearings and shaft donated	X	
Pulley	2	\$ 20.00	\$ 40.00			X	
Drive belt	1	\$ 10.00	\$ 10.00			X	
Pitching Wheel	1	\$ 65.00	\$ 65.00			X	
Spring	1	\$ 1.00	\$ 1.00			X	
Pins	1	\$ 1.00	\$ 1.00			X	
2-13/16" - 3-3/4" Adjustable Hose Clamps	2	\$ 1.00	\$ 1.00			X	
3" PVC pipe, schedule 40	6in	\$ 2.00	\$ 2.00			X	
1/4" Plate	3 Square Feet	\$ 25.00	\$ 25.00			X	
1/8" Plate	3 Square Feet	\$ 25.00	\$ 25.00			X	
Pipe, 6" OUTSIDE Diameter, 1/4" thick wall	1ft	\$ 50.00	\$ 50.00			X	
1-1/4" Square Tubing, 1/8" thick	2ft	\$ 2.00	\$ 2.00			X	
1/2" x 1/2" Angle	6in	\$ 2.00	\$ 2.00			X	
1-1/2" x 1-1/2" Angle	3-1/4"	\$ 2.00	\$ 2.00			X	
Eric's Misc		\$ 175.00	\$ 175.00			X	
Total			\$ 1,577.00	\$ 500.00			

Figure A 7-Budget

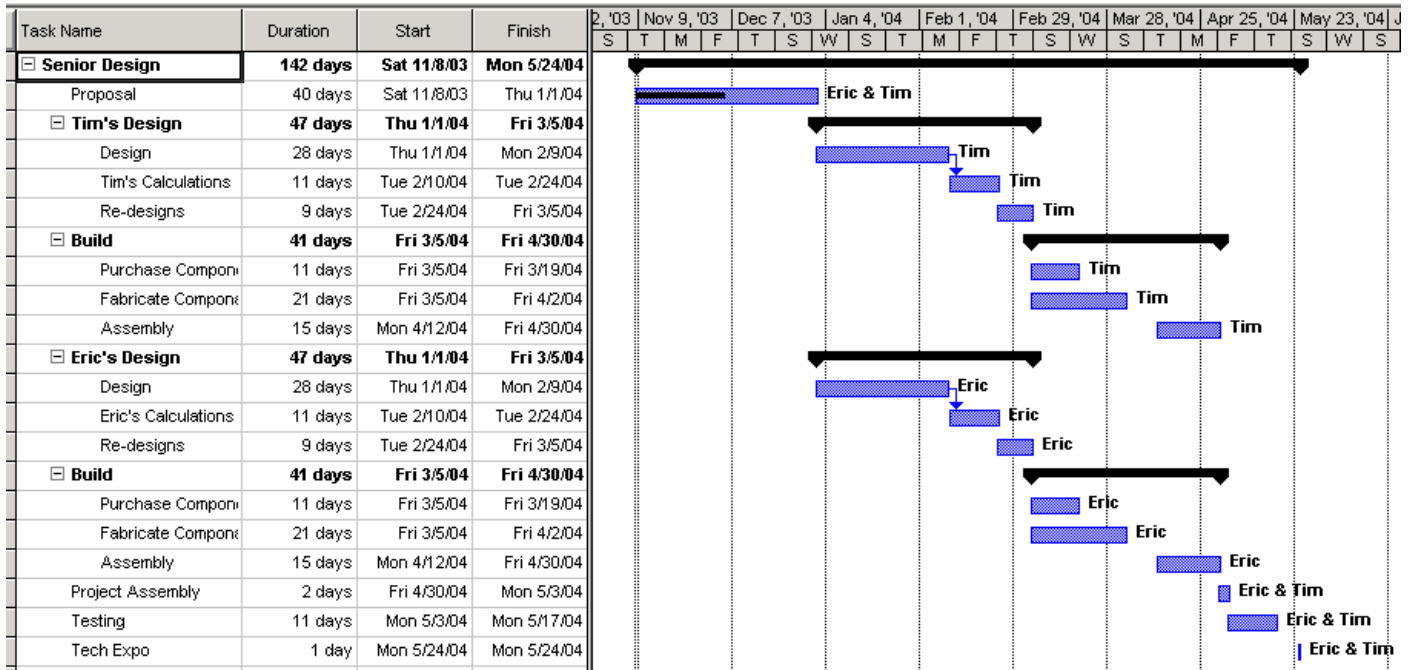

Figure A 8-Schedule

Appendix – E – Proof of Design

Appendix G

Proof of Design

The following has been agreed upon by both parties (E & T Engineering and MET Advisor – Muthar Al-Ubaidi) as critical design objectives to be verified at completion of product.

1. Automatic motion is to cover entire regulation softball field
2. Thrower must be able to throw a ball in to the outfield
3. All pinch points to be protected for safety
4. Will run off standard 110 AC power
5. Automatic feeder will supply at least 30 balls with out failure

E & T Engineering

Eric Huhn

_____ Date 4/14/04

Tim Noel



_____ Date 4/14/04

MET Adviser – Muthar Al-Ubaidi

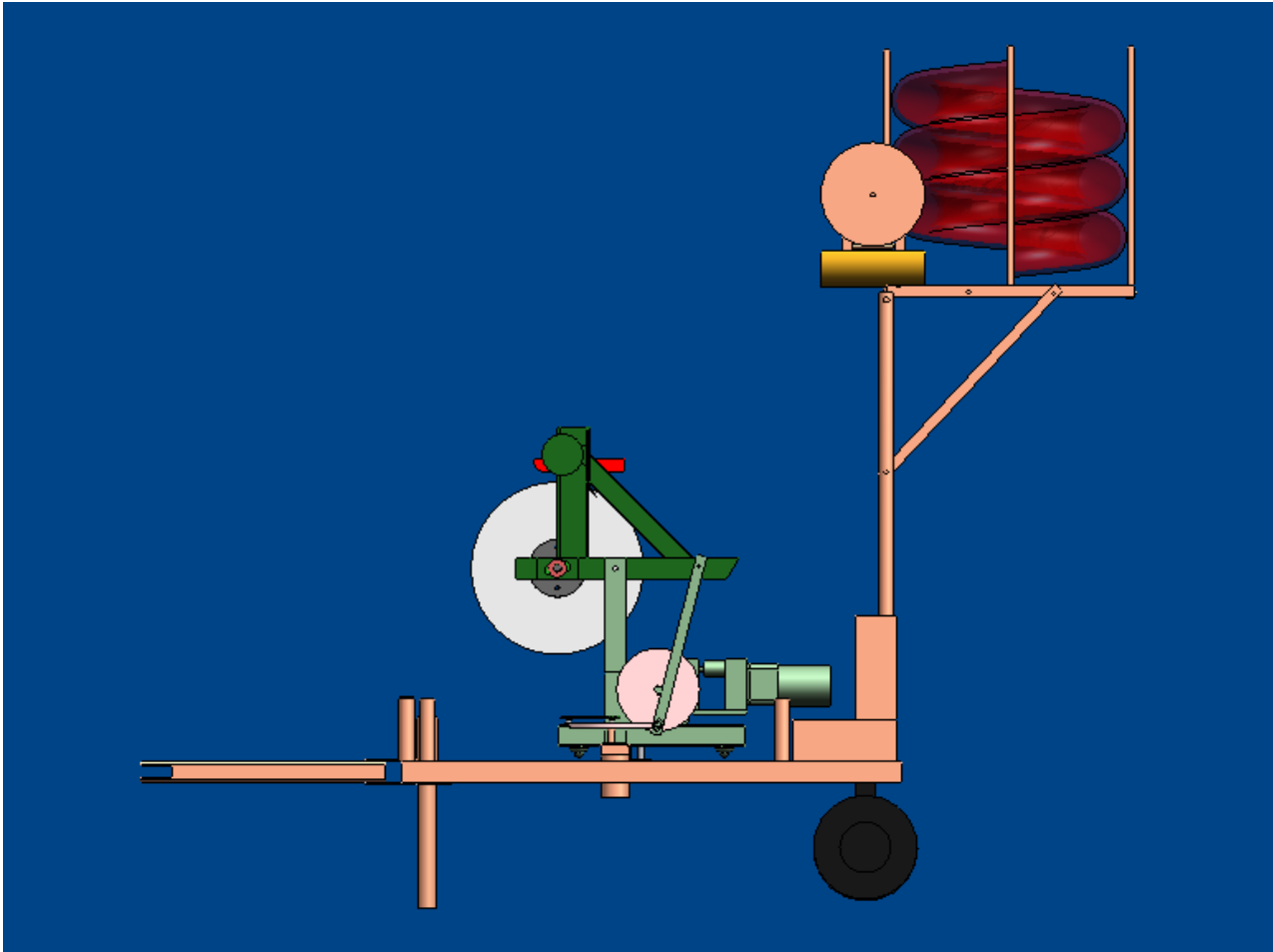

_____ Date 4/14/04

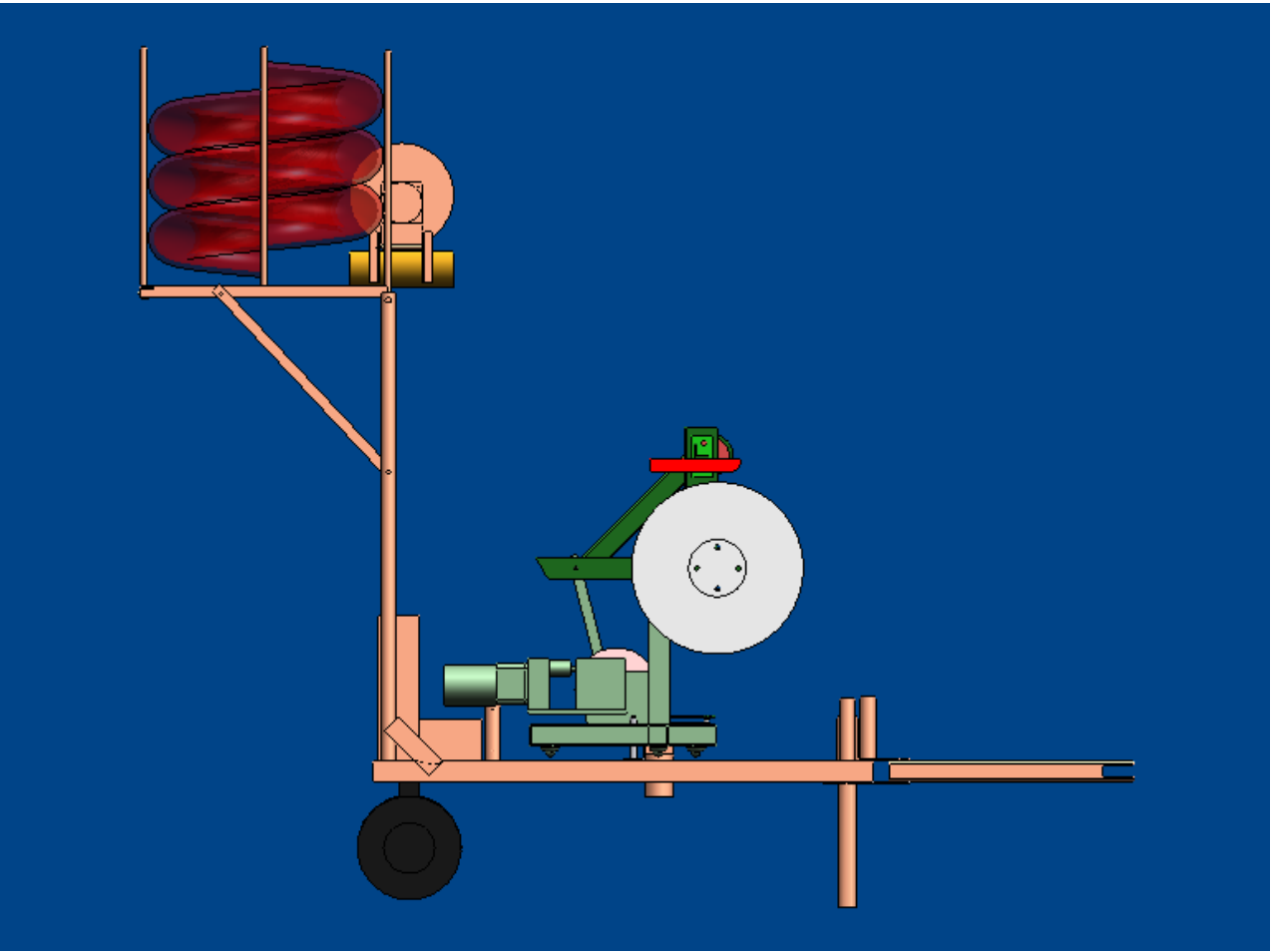
Appendix – F – Drawings & 3D Models



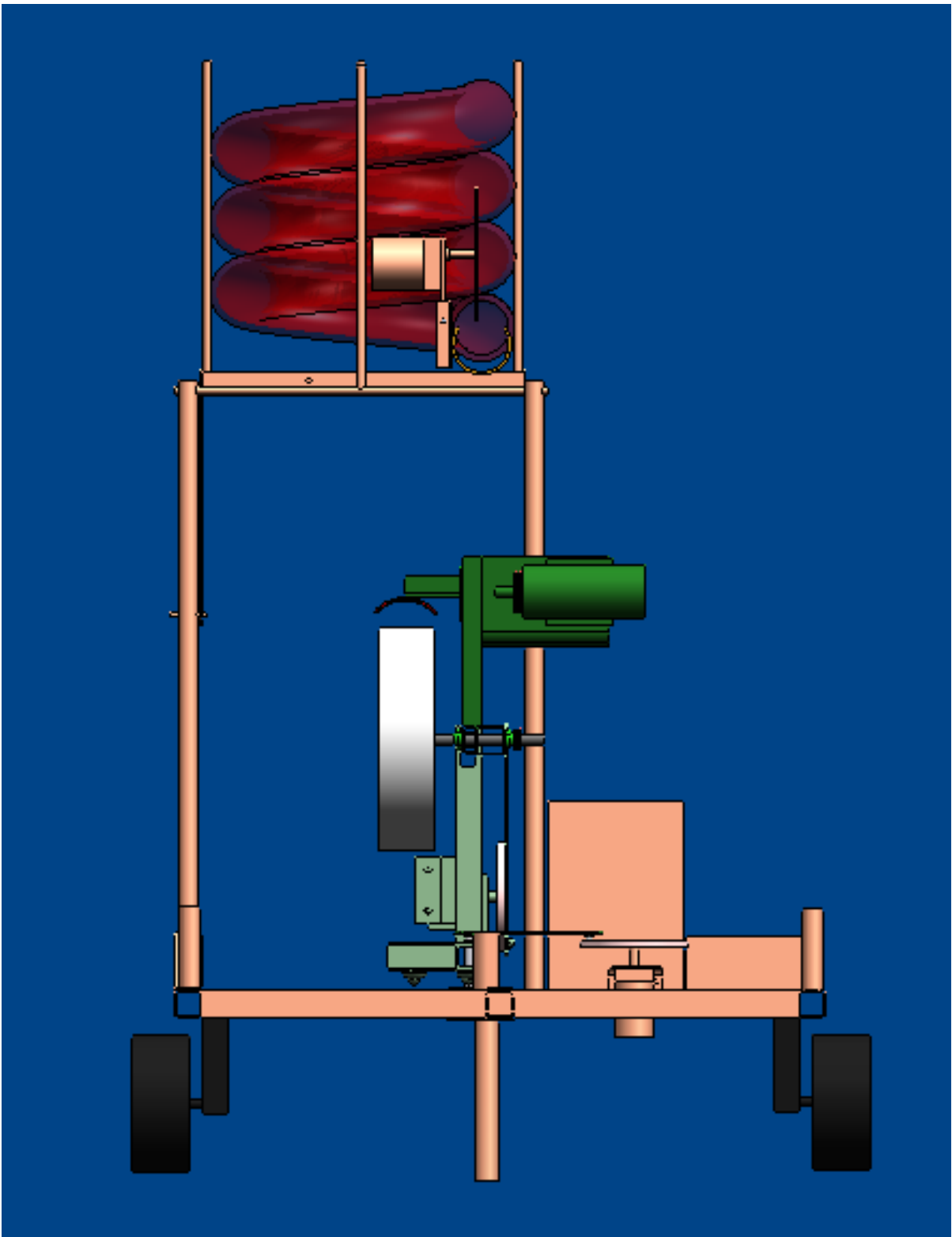

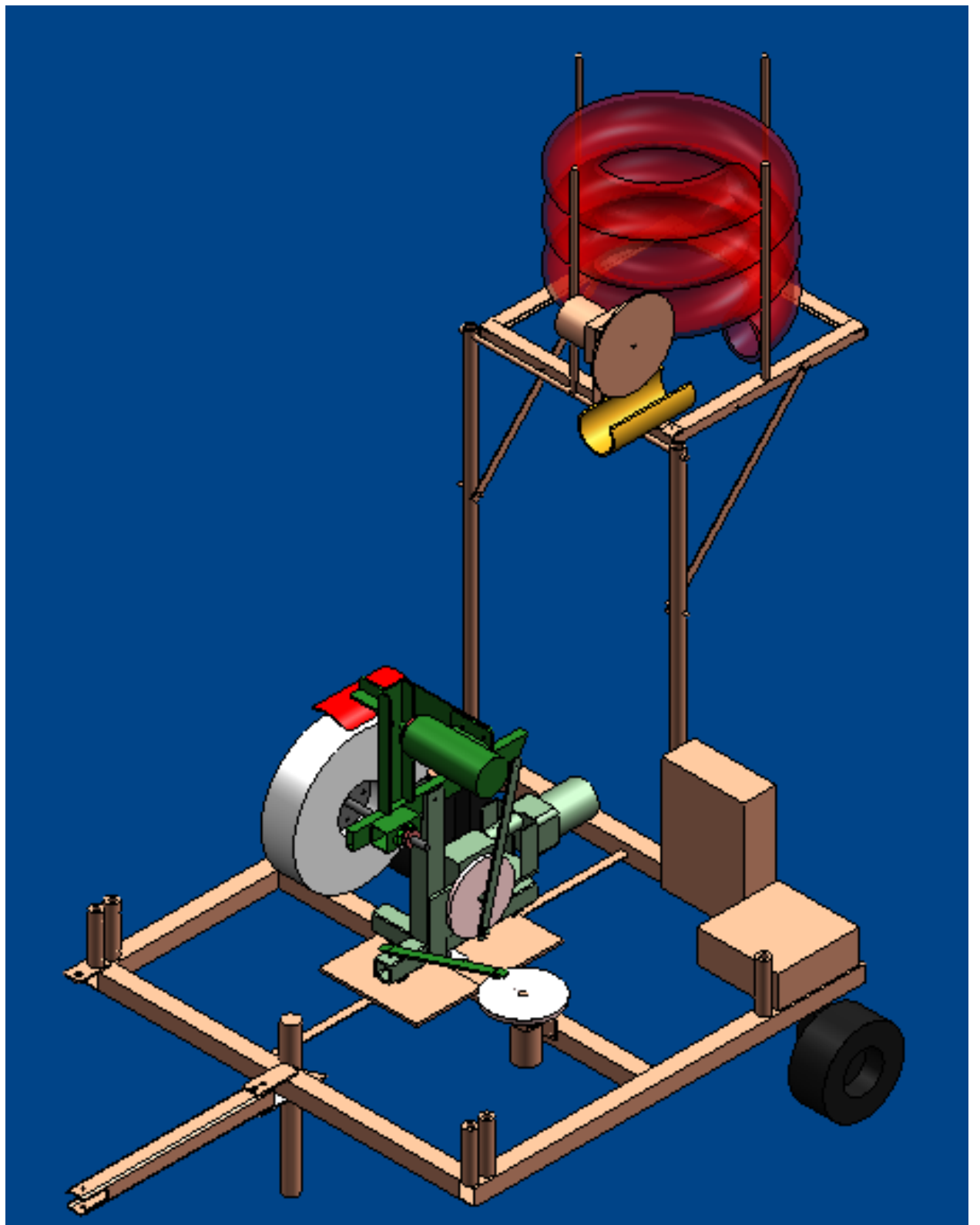



Item Number	Document Number	Title	Material	Quantity	Author
1	PT - 014	Frame	steel	1	Tim Noel
2	F-001	Tube Frame Support	steel	1	Tim Noel
3	H-001	Horizontal Motor Mount	steel	1	Tim Noel
4	H-002	Horizontal Motor	brass	1	Tim Noel
5	H-003	Motion Cam Disk	steel	2	Tim Noel
6	PT - 015	Ground Wheel Support	steel	2	Tim Noel
7	PT - 022	Trailer Jack	steel	1	Tim Noel
8	PT - 021	Hopper Support Plate	steel	2	Eric Huhn
9	H-018	Horizontal Support Angle Back	steel	1	Tim Noel
10	H-005	Horizontal Support Angle Front	steel	1	Tim Noel
11	H-006	Horizontal Pivot Pin	steel	1	Tim Noel
12	H-000	Horizontal Assembly		1	Tim Noel
13	HA-000	Hopper Assy		1	Eric huhn
14	H-014	Guard Support	steel	5	Tim Noel
15	H-017	Electrical Box 1	aluminum	1	Tim Noel
16	H-016	Electrical Box 2	aluminum	1	Tim Noel
17	BF-009	Hopper Support Angle	steel	1	Eric Huhn
18	F-011	Hitch Support	steel	2	Tim Noel
19	F-010	Hitch Holder	steel	1	Tim Noel
20	F-012	Hitch	steel	1	Tim Noel
21	V-000	Vertical Assembly		1	Tim Noel
22'	VL-001	Vertical Link Assembly		1	Tim Noel
23	HL-001	Horizontal Link Assembly		1	Tim Noel

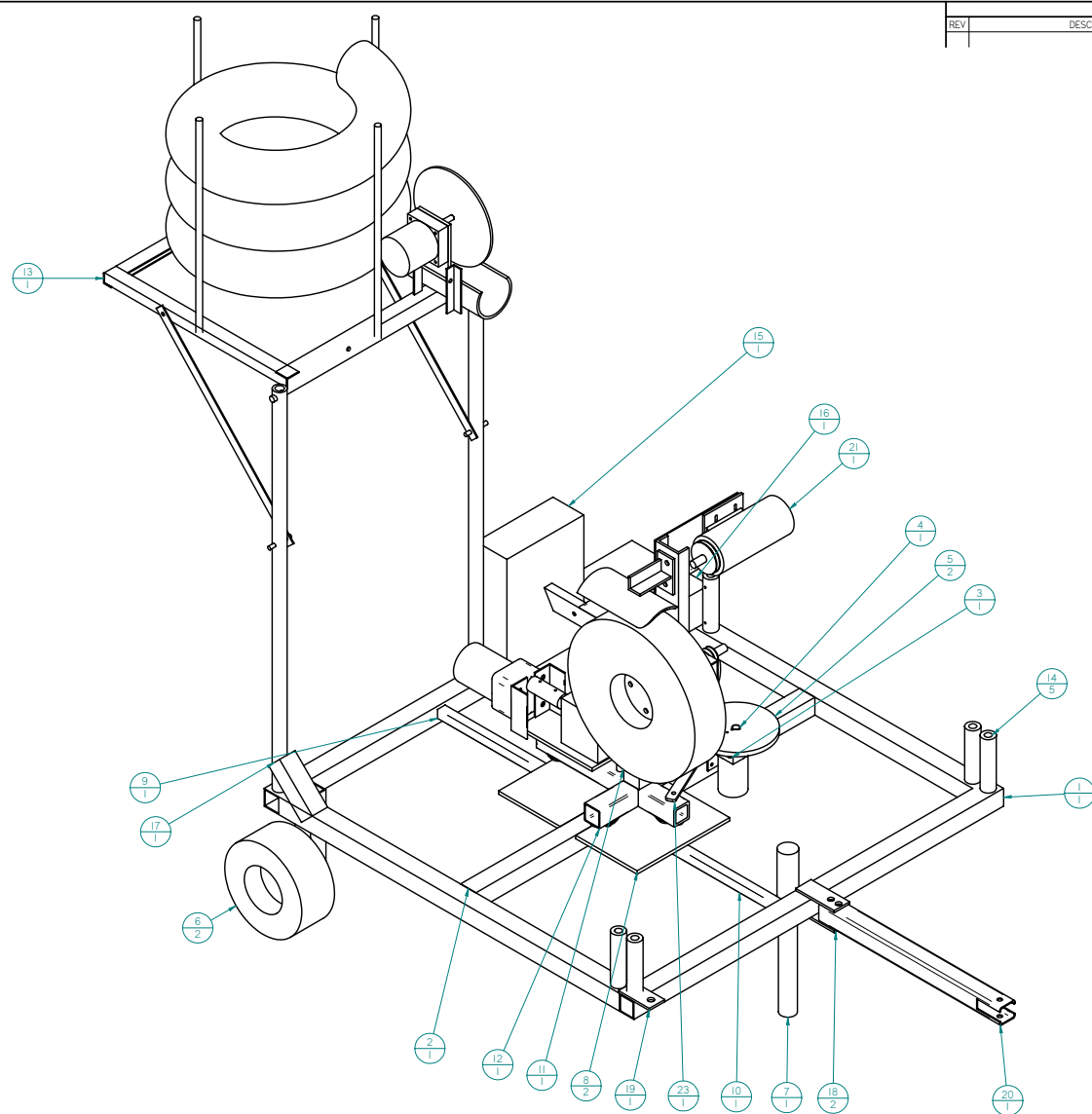

REVISION HISTORY			
REV	DESCRIPTION	DATE	APPROVED

DRAWN	NAME	DATE	SOLID EDGE	
CHECKED	Tim Noel	05/29/04	EDS-PLM SOLUTIONS	
ENG APPR			The 11th Man	
MGR APPR			SIZE	REV
			D	A
UNLESS OTHERWISE SPECIFIED DIMENSIONS ARE IN INCHES ANGLES °XX'			FILE NAME	MFA-000
2 PL *XXX 3 PL *XXXX			SCALE	WEIGHT
			SHEET 1 OF 3	

SOLID EDGE ACADEMIC COPY

Item Number	Document Number	Title	Material	Quantity	Author
1	PT - 014	Frame	steel	1	Tim Noel
2	F-001	Tube Frame Support	steel	1	Tim Noel
3	H-001	Horizontal Motor Mount	steel	1	Tim Noel
4	H-002	Horizontal Motor	brass	1	Tim Noel
5	H-003	Motion Cam Disk	steel	2	Tim Noel
6	PT - 015	Ground Wheel Support	steel	2	Tim Noel
7	PT - 022	Trailer Jack	steel	1	Tim Noel
8	PT - 021	Hopper Support Plate	steel	2	Eric Huhn
9	H-018	Horizontal Support Angle Back	steel	1	Tim Noel
10	H-005	Horizontal Support Angle Front	steel	1	Tim Noel
11	H-006	Horizontal Pivot Pin	steel	1	Tim Noel
12	H-000	Horizontal Assembly		1	Tim Noel
13	HA-000	Hopper Assy		1	Eric huhn
14	H-014	Guard Support	steel	5	Tim Noel
15	H-017	Electrical Box 1	aluminum	1	Tim Noel
16	H-016	Electrical Box 2	aluminum	1	Tim Noel
17	BF-009	Hopper Support Angle	steel	1	Eric Huhn
18	F-011	Hitch Support	steel	2	Tim Noel
19	F-010	Hitch Holder	steel	1	Tim Noel
20	F-012	Hitch	steel	1	Tim Noel
21	V-000	Vertical Assembly		1	Tim Noel
22	VL-001	Vertical Link Assembly		1	Tim Noel
23	HL-001	Horizontal Link Assembly		1	Tim Noel

REVISION HISTORY			
REV	DESCRIPTION	DATE	APPROVED

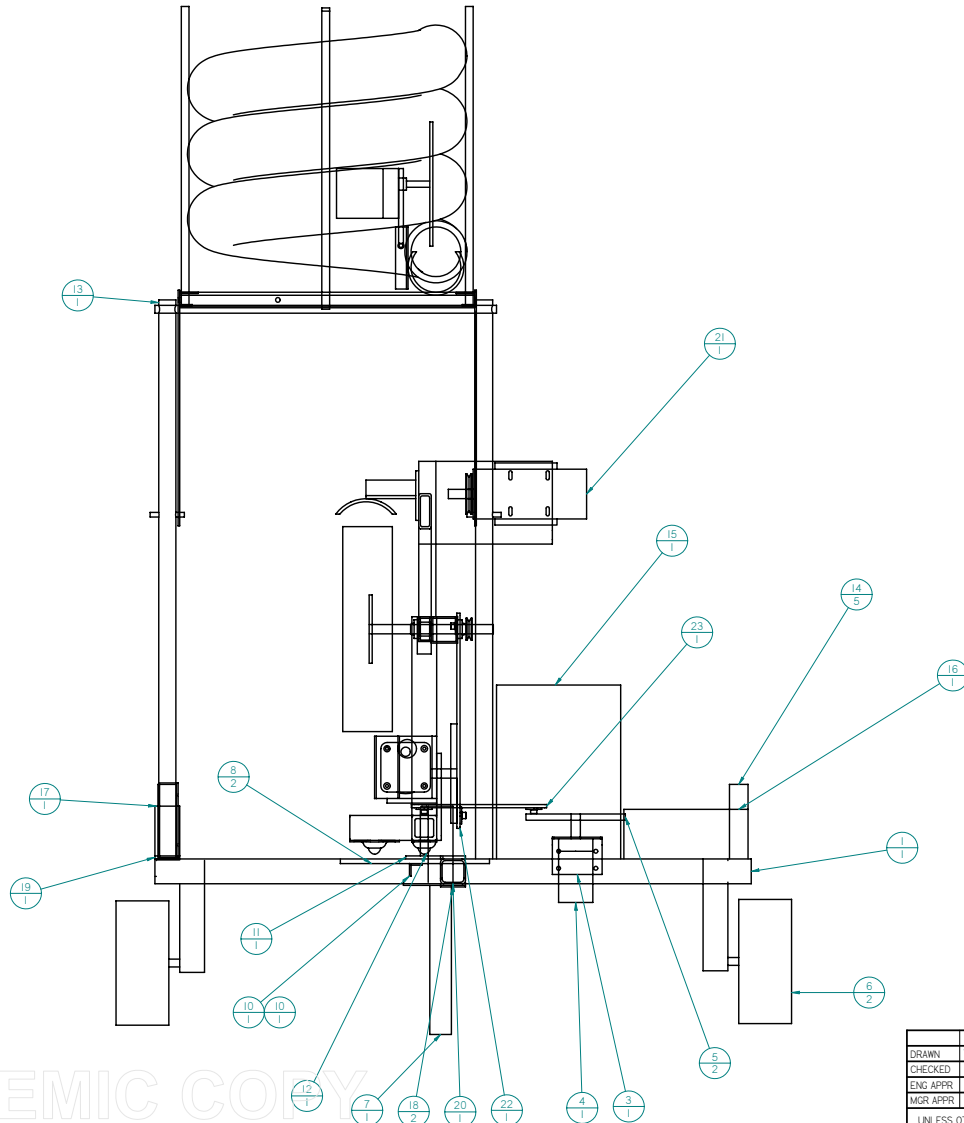

DRAWN	NAME	DATE	SOLID EDGE	
CHECKED	Tim Noel	05/29/04	EDS-PLM SOLUTIONS	
ENG APPR			The 11th Man	
MGR APPR			SIZE	REV
			D	A
UNLESS OTHERWISE SPECIFIED DIMENSIONS ARE IN INCHES ANGLES °XX'			FILE NAME	MFA-000
2 PL *XXX 3 PL *XXXX			SCALE	WEIGHT
			SHEET 2 OF 3	

Item Number	Document Number	Title	Material	Quantity	Author
1	PT - 014	Frame	steel	1	Tim Noel
2	F-001	Tube Frame Support	steel	1	Tim Noel
3	H-001	Horizontal Motor Mount	steel	1	Tim Noel
4	H-002	Horizontal Motor	brass	1	Tim Noel
5	H-003	Motion Cam Disk	steel	2	Tim Noel
6	PT - 015	Ground Wheel Support	steel	2	Tim Noel
7	PT - 022	Trailer Jack	steel	1	Tim Noel
8	PT - 021	Hopper Support Plate	steel	2	Eric Huhn
9	H-018	Horizontal Support Angle Back	steel	1	Tim Noel
10	H-005	Horizontal Support Angle Front	steel	1	Tim Noel
11	H-006	Horizontal Pivot Pin	steel	1	Tim Noel
12	H-000	Horizontal Assembly		1	Tim Noel
13	HA-000	Hopper Assy		1	Eric Huhn
14	H-014	Guard Support	steel	5	Tim Noel
15	H-017	Electrical Box 1	aluminum	1	Tim Noel
16	H-016	Electrical Box 2	aluminum	1	Tim Noel
17	BF-009	Hopper Support Angle	steel	1	Eric Huhn
18	F-011	Hitch Support	steel	2	Tim Noel
19	F-010	Hitch Holder	steel	1	Tim Noel
20	F-012	Hitch	steel	1	Tim Noel
21	V-000	Vertical Assembly		1	Tim Noel
22	VL-001	Vertical Link Assembly		1	Tim Noel
23	HL-001	Horizontal Link Assembly		1	Tim Noel

REVISION HISTORY			
REV	DESCRIPTION	DATE	APPROVED

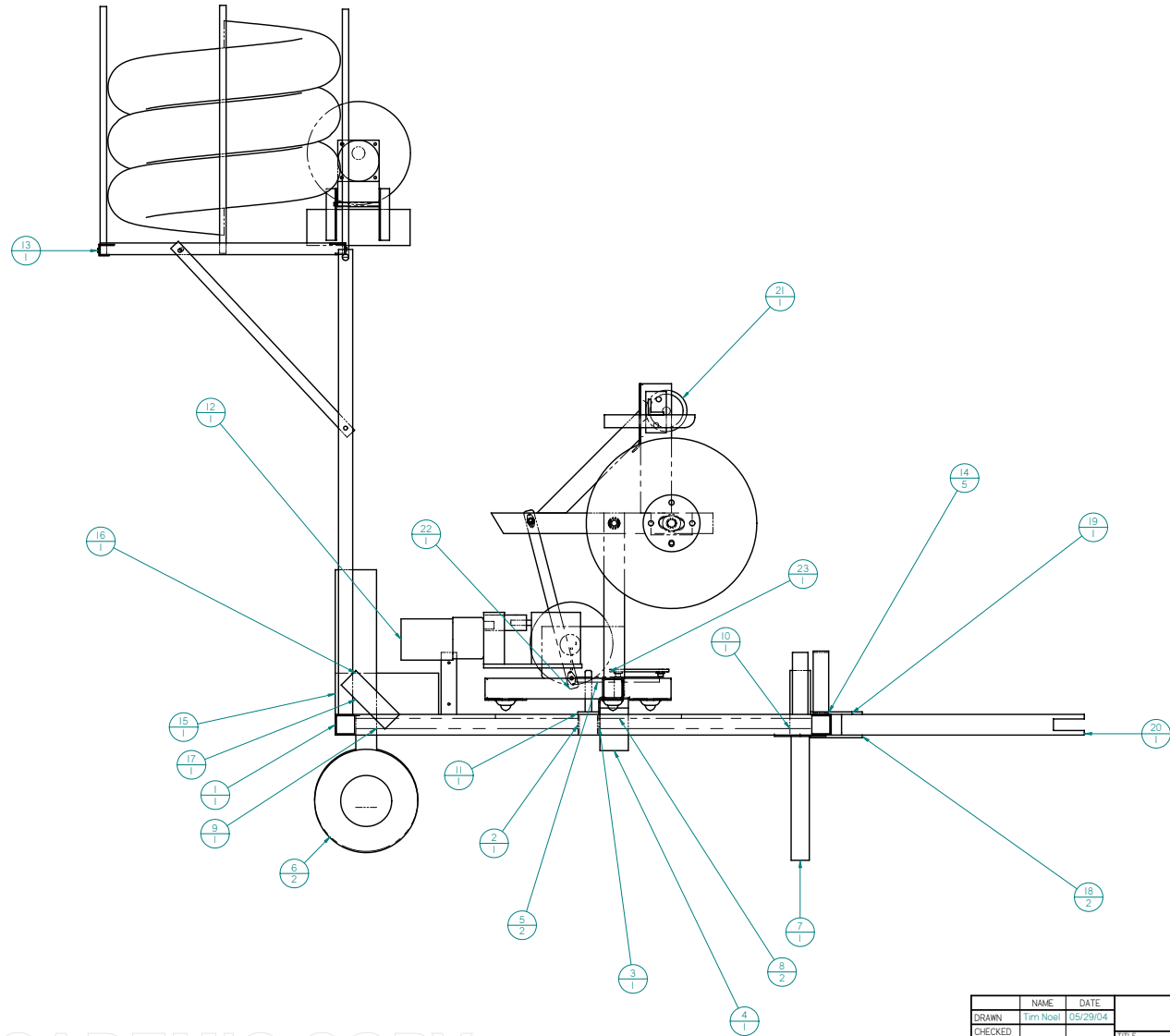

SOLID EDGE ACADEMIC COPY

DRAWN	NAME	DATE	SOLID EDGE	
CHECKED	Tim Noel	05/29/04	EDS-PLM SOLUTIONS	
ENG APPR			The 11th Man	
MGR APPR			SIZE	REV
			D	A
UNLESS OTHERWISE SPECIFIED DIMENSIONS ARE IN INCHES ANGLES °XX'			FILE NAME	MFA-000
2 PL. XXXX 3 PL. XXXX			SCALE	WEIGHT
			SHEET 3 OF 3	

Item Number	Document Number	Title	Material	Quantity	Author	Item Number	Document Number	Title	Material	Quantity	Author
1	V-008	Up_Right Support	steel	1	Tim Noel	11	V-011	Pitching Wheel	aluminum	1	Eric Huhn
2*	V-002	Vertical Support Leg	steel	1	Tim Noel	12	V-012	Motor Mount Plate	steel	1	Eric Huhn
3	V-004	Vertical Support Bearing	steel	1	Tim Noel	13	V-020	Pitching Motor	brass	1	Tim Noel
4	V-001	Shaft Support	steel	1	Tim Noel	14*	V-021	Motor Pulley	aluminum	1	Tim Noel
5*	V-003	Shaft Bearing	Bearing	2	Tim Noel	15	V-021	Shaft Pulley	aluminum	1	Tim Noel
6	V-007	Wheel Shaft	steel	1	Tim Noel	16	Z-022	Thrower Support	steel	1	Tim Noel
7	V-008	Wheel Hub	steel	1	Tim Noel						
8	V-010	Flat Plate Ball Mount	steel	1	Eric Huhn						
9	V-005	Angle Support	steel	1	Tim Noel						
10	V-009	Ball Thrower Friction Plate	steel	1	Tim Noel						

REVISION HISTORY			
REV	DESCRIPTION	DATE	APPROVED

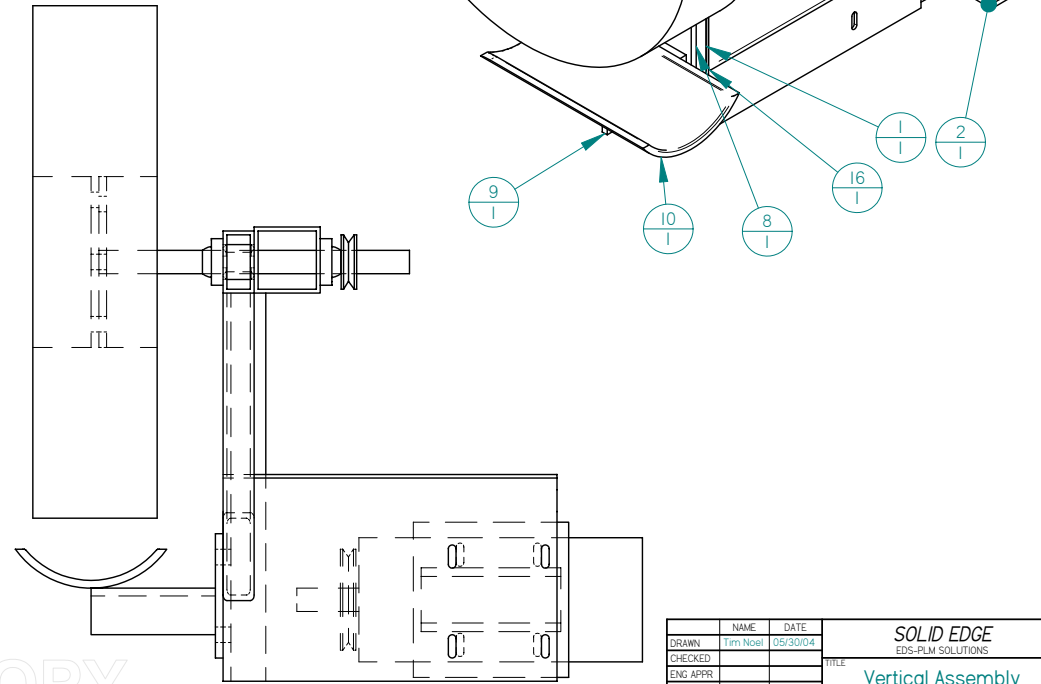
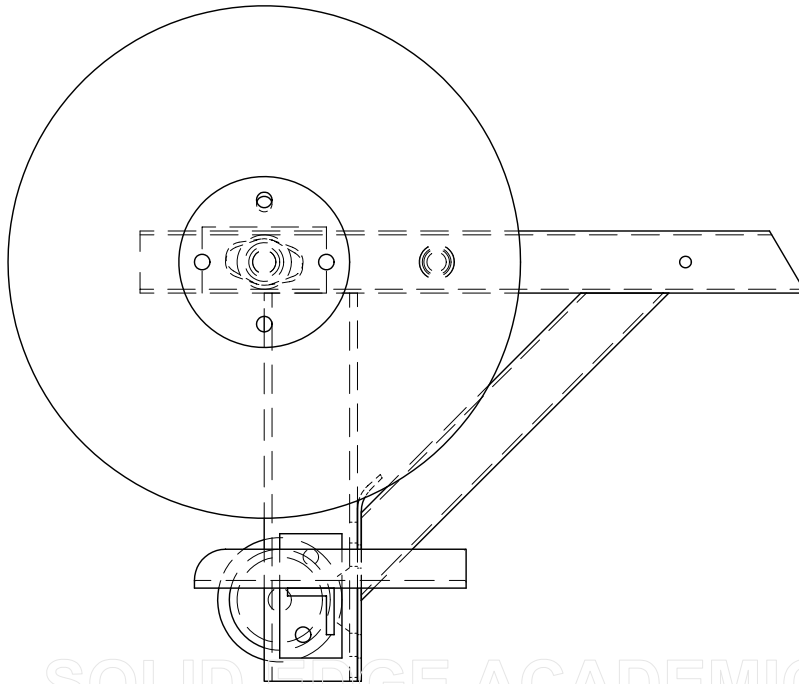

SOLID EDGE ACADEMIC COPY

DRAWN	NAME	DATE	SOLID EDGE	
CHECKED	Tim Noel	05/30/04	EDS-PLM SOLUTIONS	
ENG APPR			Vertical Assembly	
MGR APPR			SIZE	REV
UNLESS OTHERWISE SPECIFIED DIMENSIONS ARE IN INCHES ANGLES =XX°			D	A
2 PL *XXX 3 PL *XXXX			DWG NO	FILE NAME
			V-000	Vertical Assy - 2dft
			SCALE	WEIGHT
				SHEET 1 OF 1

Item Number	Document Number	Title	Material	Quantity	Author
1	H-007	Horizontal Support Link Lower	steel	1	Tim Noel
2	PT - 037	Support Bearing for Horizontal	Bearing	3	Tim Noel
3	H-008	Upright Leg	steel	1	Tim Noel
4	H-011	Gear Box Support Plate 1	steel	1	Tim Noel
5	H-012	Gear Box Support Plate 2	steel	1	Tim Noel
6	H-010	Gear Box	aluminum	1	Tim Noel
7	H-013	Gear Box Coupler	steel	1	Tim Noel
8	H-014	Vertical Support Motor Angle	steel	2	Tim Noel
9	H-014	Vertical Motor	brass	1	Tim Noel

REVISION HISTORY			
REV	DESCRIPTION	DATE	APPROVED

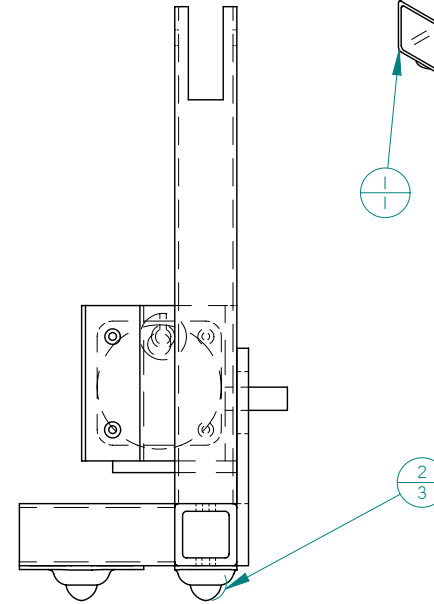
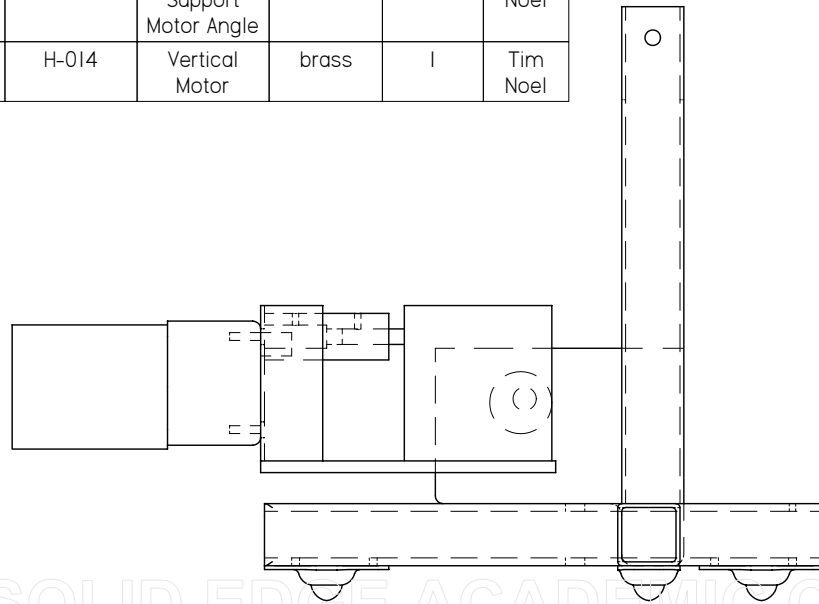
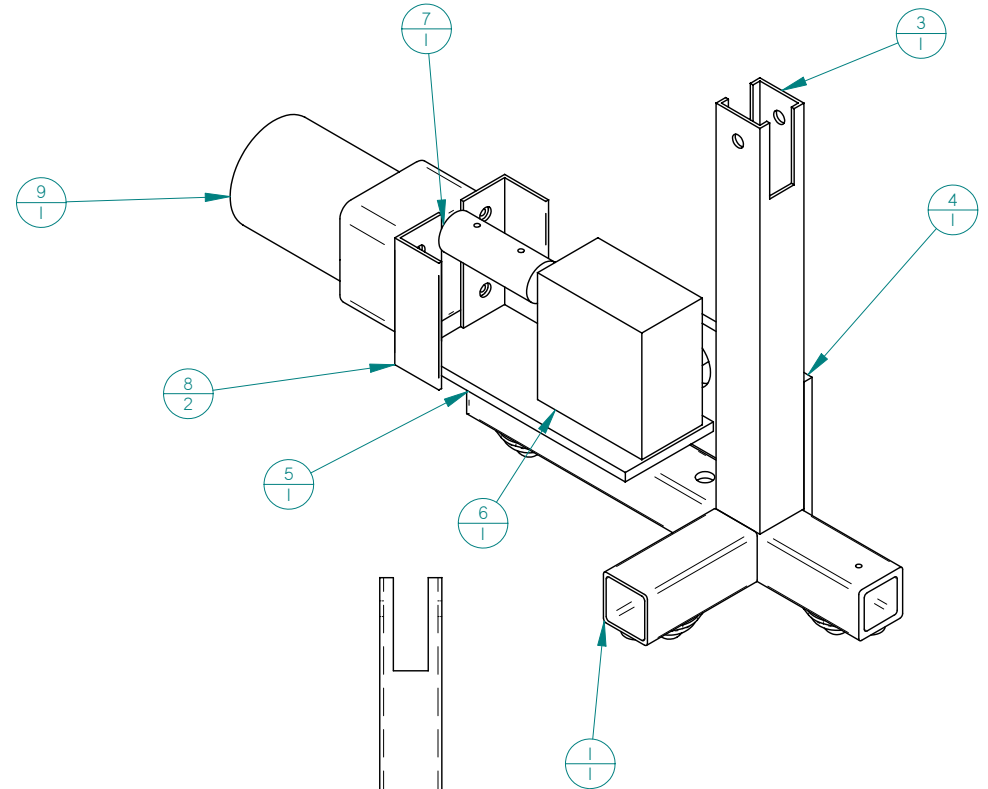

SOLID EDGE ACADEMIC COPY

DRAWN	NAME	DATE	SOLID EDGE	
CHECKED	Tim Noel	05/29/04	EDS-PLM SOLUTIONS	
ENG APPR			Horizontal Assembly	
MGR APPR			SIZE	REV
			D	A
UNLESS OTHERWISE SPECIFIED DIMENSIONS ARE IN INCHES ANGLES ±XX°			DWG NO	H-000
2 PL ±XXX 3 PL ±XXXX			FILE NAME	Horizontal Assy.dft
SCALE	WEIGHT	SHEET 1 OF 1		

Item Number	Document Number	Title	Material	Quantity	Author
1	BF-006	Hopper Frame Floor	steel	4	Eric Huhn
2	PT - 032	Pivot Rod for Hopper	steel	1	Eric Huhn
3	Assy-001	Ball Feeder Motor Assembly		1	Eric Huhn
4	BF-007	Hopper Hose	Plastic	1	Eric Huhn
5	BF-008	Hopper Frame Post	steel	4	Eric Huhn

REVISION HISTORY			
REV	DESCRIPTION	DATE	APPROVED

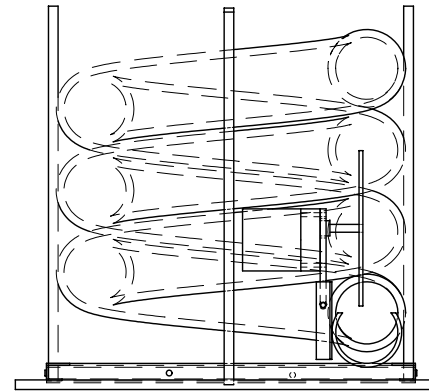
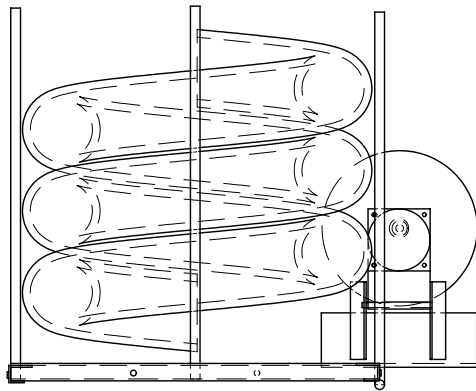
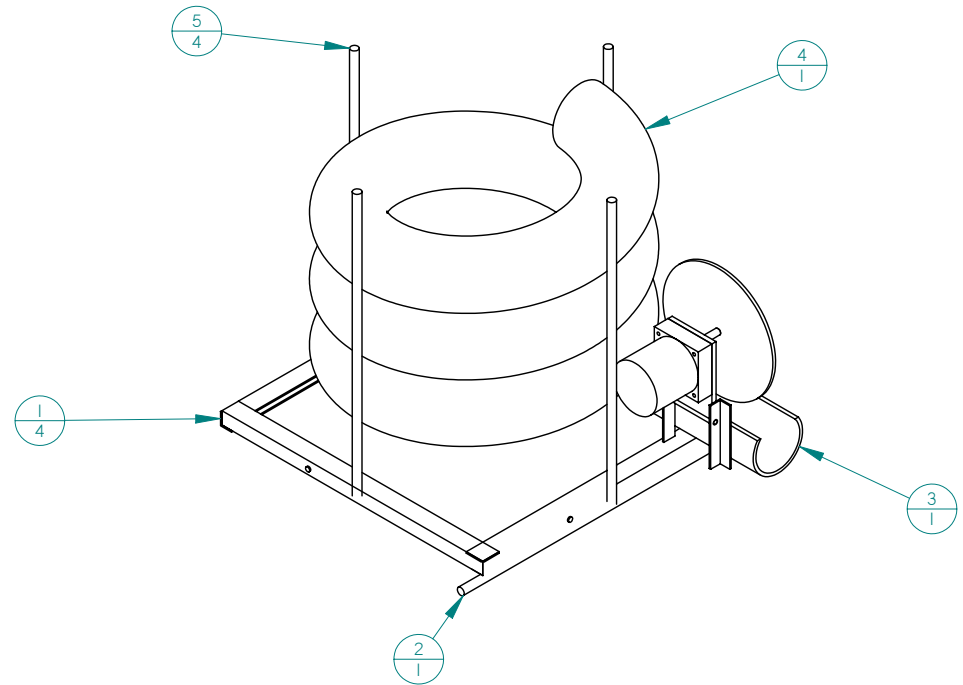

SOLID EDGE ACADEMIC COPY

DRAWN	Eric Huhn	DATE	05/29/04	SOLID EDGE EDS-PLM SOLUTIONS	
CHECKED		TITLE		Hopper Assembly	
ENG APPR		SIZE	DWG NO	REV	
MGR APPR		D	HA-000	A	
UNLESS OTHERWISE SPECIFIED DIMENSIONS ARE IN INCHES ANGLES °XX'			FILE NAME	Hopper Assy.dft	
2 PL *XXX 3 PL *XXXX		SCALE	WEIGHT	SHEET 1 OF 1	

Item Number	Document Number	Title	Material	Quantity	Author
1	MA-020	Vertical Link	steel	1	Tim Noel
2	HVA-001	Link Bearing	aluminum	2	Tim Noel

REVISION HISTORY			
REV	DESCRIPTION	DATE	APPROVED

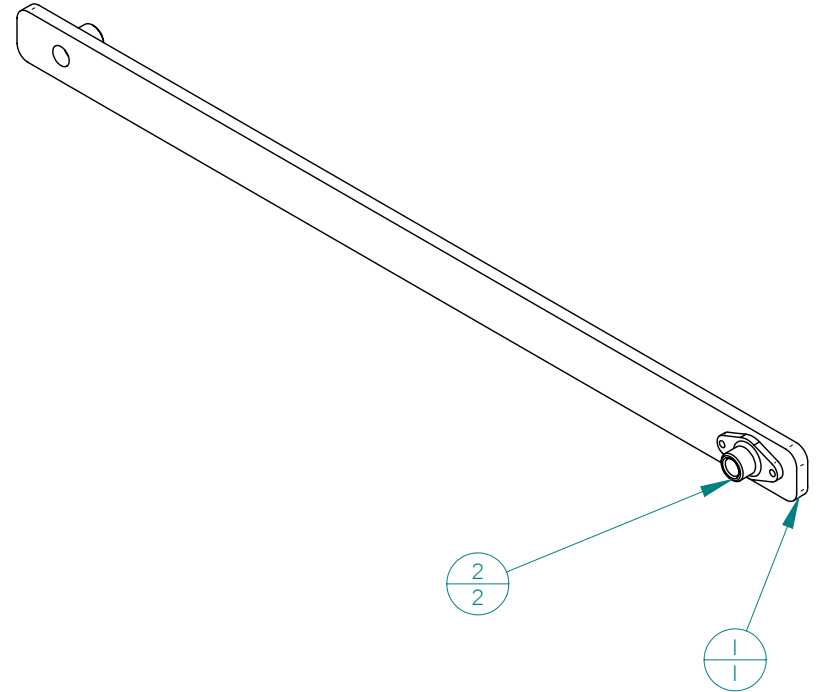

SOLID EDGE ACADEMIC COPY

DRAWN	NAME	DATE	SOLID EDGE	
CHECKED	Tim Noel	05/30/04	EDS-PLM SOLUTIONS	
ENG APPR			Vertical Link Assembly	
MGR APPR			SIZE	REV
UNLESS OTHERWISE SPECIFIED DIMENSIONS ARE IN INCHES ANGLES ±XX° 2 PL ±XXX 3 PL ±XXXX			D	A
			FILE NAME: Vertical Link.dft	
			SCALE:	WEIGHT: SHEET 1 OF 1

Item Number	Document Number	Title	Material	Quantity	Author
1	MA-020	Vertical Link	steel	1	Tim Noel
2	HVA-001	Link Bearing	aluminum	2	Tim Noel

REVISION HISTORY			
REV	DESCRIPTION	DATE	APPROVED

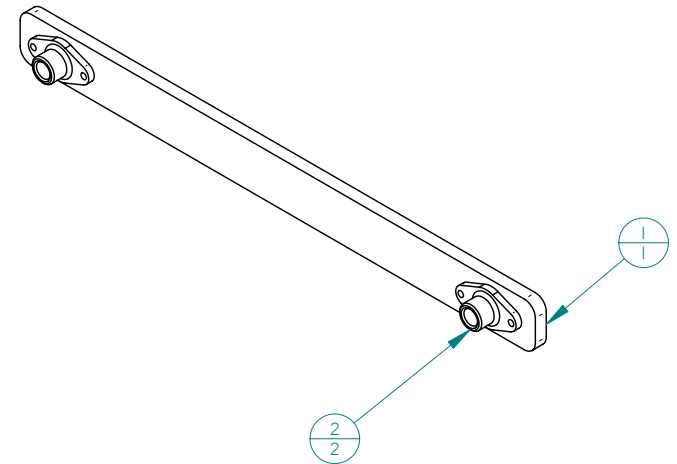

SOLID EDGE ACADEMIC COPY

DRAWN	NAME	DATE	SOLID EDGE	
CHECKED	Tim Noel	05/30/04	EDS-PLM SOLUTIONS	
ENG APPR			Vertical Link Assembly	
MGR APPR			SIZE	REV
UNLESS OTHERWISE SPECIFIED DIMENSIONS ARE IN INCHES ANGLES ±XX°			D	A
2 PL ±XXX 3 PL ±XXXX			DWG NO	FILE NAME
			VLA-001	Horizontal Link Assy.dft
			SCALE	WEIGHT
				SHEET 1 OF 1

Item Number	Document Number	Title	Material	Quantity	Author
1	PT - 006	Ball Feeder Pipe	steel	1	Eric Huhn
2	BF-002	Ball Feeder Motor Pivot	steel	1	Eric Huhn
3	BF-003	Ball Feeder Motor Pivot - 2	steel	1	Eric Huhn
4	BF-001	Ball Feeder Motor Support	steel	1	Eric Huhn
5	ASSY - 001	Ball Feeder Motor Assy	Motor	1	Eric Huhn
6	BF-004	Ball Feeder Motor Pivot Pin	steel	1	Eric Huhn
7	BF-005	Ball Feeder Wheel	aluminum	1	Eric Huhn

REVISION HISTORY			
REV	DESCRIPTION	DATE	APPROVED

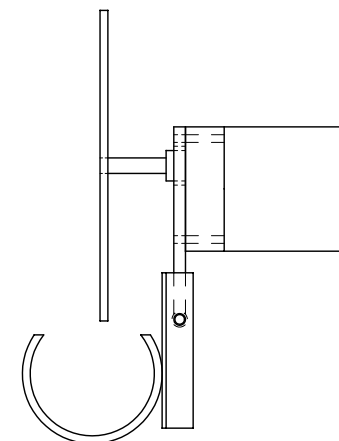
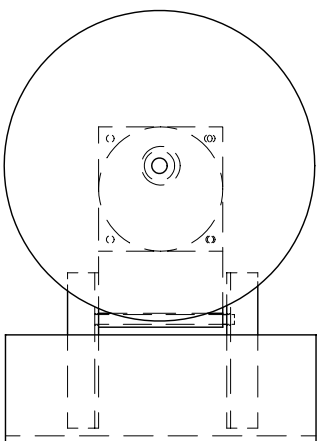
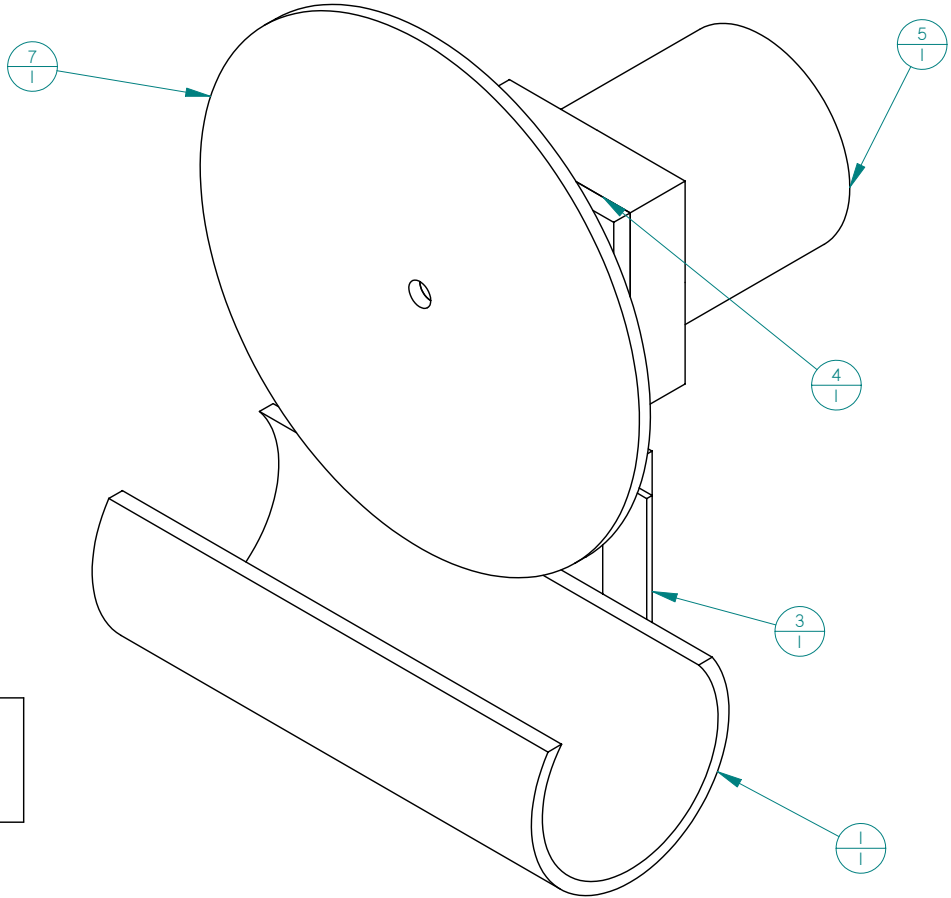

SOLID EDGE ACADEMIC COPY

NAME	DATE	SOLID EDGE	
Eric Huhn	05/29/04	EDS-PLM SOLUTIONS	
DRAWN		TITLE	
CHECKED		Ball Feeder Motor Assembly	
ENG APPR		SIZE DWG NO	
MGR APPR		D BF-001	
UNLESS OTHERWISE SPECIFIED		REV	
DIMENSIONS ARE IN INCHES		A	
ANGLES: °XX'		FILE NAME: Ball-Feeder-Motor-Assy.dft	
2 PL: *XXX 3 PL: *XXXX		SCALE: WEIGHT: SHEET 1 OF 1	

Item Number	Document Number	Title	Material	Quantity	Author
1	PT - 020	Hopper Support Bar	steel	1	Eric Huhn
2	BF-006	Hopper Frame Floor	steel	1	Eric Huhn
3	PT - 016	Hopper Support Arm	steel	1	Eric Huhn

REVISION HISTORY			
REV	DESCRIPTION	DATE	APPROVED

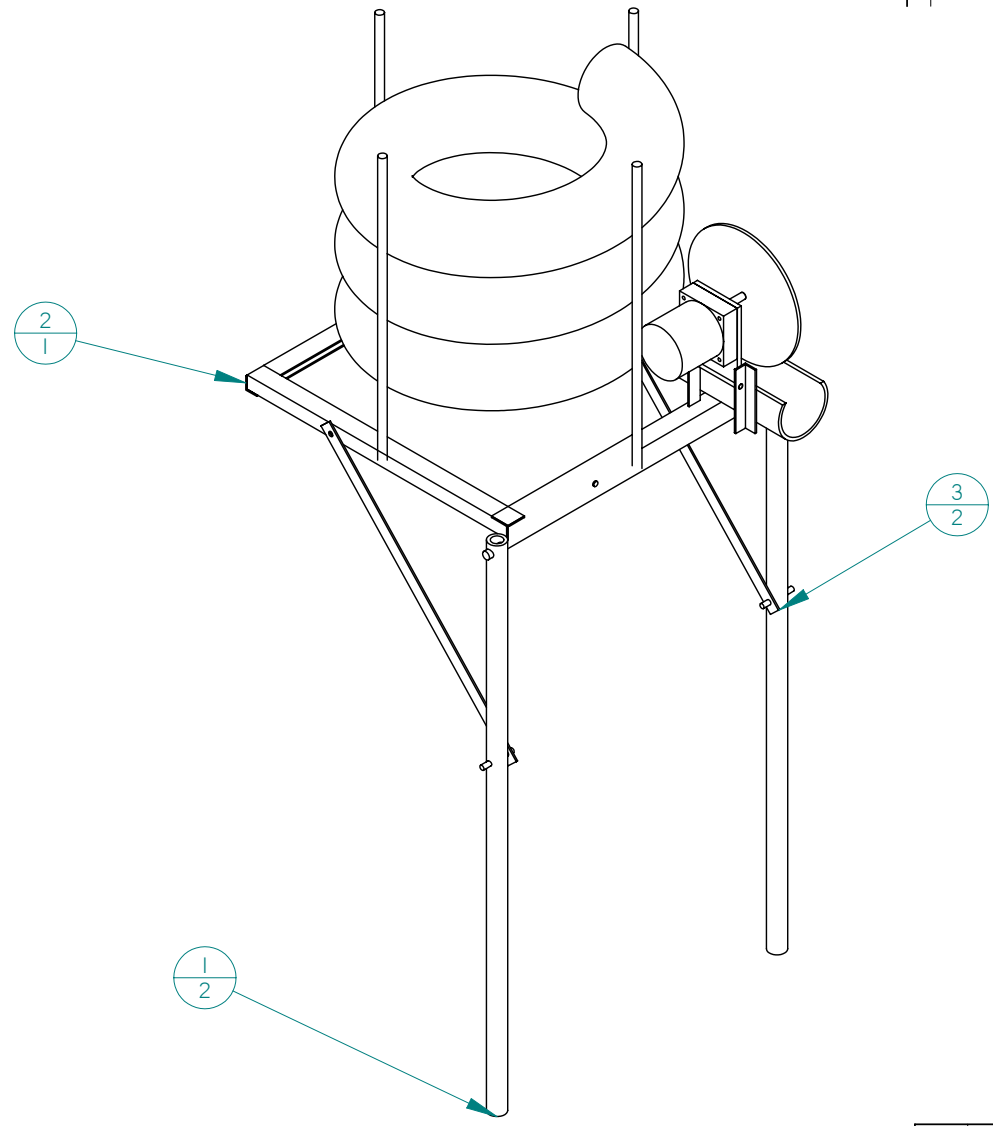

SOLID EDGE ACADEMIC COPY

DRAWN	Eric Huhn	DATE	05/29/04	SOLID EDGE	
CHECKED				EDS-PLM SOLUTIONS	
ENG APPR				TITLE: Hopper Support Assembly	
MGR APPR				SIZE: D	DWG NO: HA-000
UNLESS OTHERWISE SPECIFIED DIMENSIONS ARE IN INCHES ANGLES: °XX'				REV: A	FILE NAME: Hopper Support Assy.dft
2 PL: XXXX 3 PL: XXXX				SCALE:	WEIGHT: SHEET 1 OF 2

REVISION HISTORY			
REV	DESCRIPTION	DATE	APPROVED

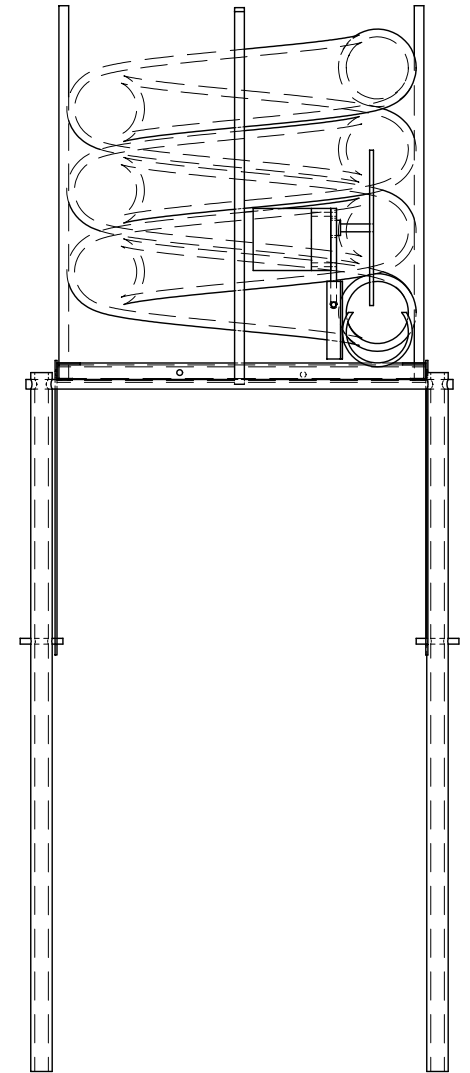
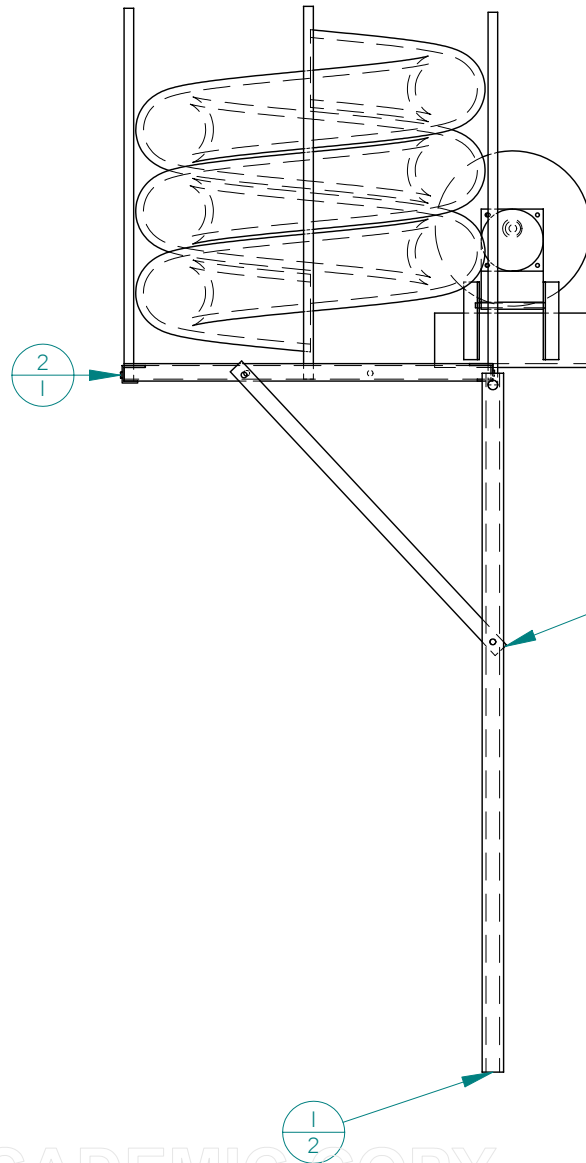

SOLID EDGE ACADEMIC COPY

DRAWN	NAME	DATE	SOLID EDGE	
CHECKED	Eric Huhn	05/29/04	EDS-PLM SOLUTIONS	
ENG APPR			Hopper Support Assembly	
MGR APPR			SIZE	REV
UNLESS OTHERWISE SPECIFIED DIMENSIONS ARE IN INCHES ANGLES °XX'			D	A
2 PL #XXX 3 PL #XXXX			DWG NO	HA-000
			FILE NAME	Hopper Support Assy.dft
			SCALE	WEIGHT
			SHEET 2 OF 2	