

Toolbox Hatchback Mount

A Baccalaureate thesis submitted to the
Department of Mechanical and Materials Engineering
College of Engineering and Applied Science
University of Cincinnati

in partial fulfillment of the
requirements for the degree of

Bachelor of Science

in Mechanical Engineering Technology

by

Phillip Graham

April 2015

Thesis Advisor: Moise Cummings

TABLE OF CONTENTS

TABLE OF CONTENTS.....	II
LIST OF FIGURES	III
FIGURE 1: DEEZEE TOOLBOX EXAMPLE	III
FIGURE 2: FEA INNER SHELL	III
FIGURE 3: FEA OUTER SHELL	III
FIGURE 4: SKETCH OF IDEAS/CONCEPTS.....	III
FIGURE 5: SKETCH OF SLIDER CONCEPTS	III
FIGURE 6: SKETCH OF TURNTABLE MOUNT.....	III
FIGURE 7: SKETCH OF TOOLBOX.....	III
FIGURE 8: MIND MAP SKETCH.....	III
FIGURE 9: DESIGN CONCEPT (SIDE).....	III
FIGURE 10: DESIGN CONCEPT (FRONT)	III
FIGURE 11: DESIGN CONCEPT (TOP).....	III
FIGURE 12: DESIGN CONCEPT (MOUNTING ANGLE).....	III
FIGURE 13: DESIGN CONCEPT (MOUNTING BAR)	III
FIGURE 14: DESIGN CONCEPT (ISOMETRIC).....	III
FIGURE 15: DESIGN CONCEPT (TOOLBOX MOUNTING PLATE)	III
FIGURE 16: DESIGN CONCEPT (ISOMETRIC DARK)	III
FIGURE 17: DESIGN CONCEPT (TURNTABLE MOUNTING PLATE).....	III
FIGURE 18: TELESCOPIC SLIDE DRAWINGS.....	III
FIGURE 19: TURNTABLE DRAWINGS.....	III
FIGURE 20: BALL DOOR STOP.....	III
FIGURE 21: BALL DOOR STOP DRAWING.....	III
LIST OF TABLES	IV
TABLE 1: QUALITY FUNCTION DEPLOYMENT	IV
TABLE 2: SCHEDULE	IV
ABSTRACT.....	V
INTRODUCTION AND RESEARCH.....	1
PROBLEM STATEMENT.....	1
INTERVIEWS.....	1
CONCEPTS & INFORMATION	1
PURPOSE	1
SECURITY.....	1
MATERIALS.....	1
DIMENSIONS	2
BUDGET	2
SOLUTION	2
CURRENT PRODUCTS	3
CUSTOMER FEEDBACK AND OBJECTIVES	4
SURVEY ANALYSIS	4
CUSTOMER FEATURES	5
QUALITY FUNCTION DEPLOYMENT	5
DESIGN.....	5
MATERIALS/SPECIFICATIONS.....	5
STRESS ANALYSIS & CALCULATIONS.....	7

DRAWINGS.....	9
SCHEDULE & BUDGET	21
FABRICATION & TESTING.....	22
CUT LIST:.....	22
TOOLING:.....	22
CONCLUSION/RECOMMENDATIONS.....	23
WORKS CITED	23
APPENDIX A.....	25

LIST OF FIGURES

- FIGURE 1: DEEZEE TOOLBOX EXAMPLE***
- FIGURE 2: FEA INNER SHELL***
- FIGURE 3: FEA OUTER SHELL***
- FIGURE 4: SKETCH OF IDEAS/CONCEPTS***
- FIGURE 5: SKETCH OF SLIDER CONCEPTS***
- FIGURE 6: SKETCH OF TURNTABLE MOUNT***
- FIGURE 7: SKETCH OF TOOLBOX***
- FIGURE 8: MIND MAP SKETCH***
- FIGURE 9: DESIGN CONCEPT (SIDE)***
- FIGURE 10: DESIGN CONCEPT (FRONT)***
- FIGURE 11: DESIGN CONCEPT (TOP)***
- FIGURE 12: DESIGN CONCEPT (MOUNTING ANGLE)***
- FIGURE 13: DESIGN CONCEPT (MOUNTING BAR)***
- FIGURE 14: DESIGN CONCEPT (ISOMETRIC)***
- FIGURE 15: DESIGN CONCEPT (TOOLBOX MOUNTING PLATE)***
- FIGURE 16: DESIGN CONCEPT (ISOMETRIC DARK)***
- FIGURE 17: DESIGN CONCEPT (TURNTABLE MOUNTING PLATE)***
- FIGURE 18: TELESCOPIC SLIDE DRAWINGS***
- FIGURE 19: TURNTABLE DRAWINGS***
- FIGURE 20: BALL DOOR STOP***
- FIGURE 21: BALL DOOR STOP DRAWING***

LIST OF TABLES

TABLE 1: QUALITY FUNCTION DEPLOYMENT

TABLE 2: SCHEDULE

ABSTRACT

This document records the information that accompanies the conception, progress, procedures, and conclusions of my senior design project. The logical construct includes a concise statement of the perceived problem, the solution to this problem, the design objectives for this solution, the process for meeting these objectives, the proof of the validity of the process in meeting these objectives, and the conclusions and recommendations.

The toolbox mount was designed in order to meet the needs of a daily driver to the needs of a mechanically inclined individual who regularly needs to access their tools. In addition, the mount for the toolbox enables individuals to easily access the tools upon a platform without hurting their back reaching within the bed of the truck.

The mount for the toolbox is not only adaptable to different sizes and shapes that fit within the range but can be used to mount other such items upon the platform such as a grill or coolers for tailgating. This design is the first stage of several to come to make the mount extremely adaptable and versatile.

The design of this toolbox mount incorporates a very low profile design enabling the customer to mount their desired toolbox with little to no space wasted. The design also was drawn and built with the intention for any typical customer to install themselves; where there is no welding, cutting, or bending and each part is held together with nuts, bolts, washers, and screws.

Overall this completed project was a working model showing the beginning stages of design, FEA, customer input, professor advice, fabrication, and ending with a model that was displayed at the tech show- with knowledge and plans to take in customer feedback and build and change things to increase the design of the overall product .

INTRODUCTION AND RESEARCH***PROBLEM STATEMENT***

Toolboxes tend to take up most of the trunk space of vehicles leaving little to no room for other storage. However, many vehicle owners look to keep tools on them most of the time to address any roadside emergencies and or for daily use. Tools can be costly, heavy, and easily lost within tool bags.

The proposed solution would be to design a toolbox mount that is vertically integrated within the side of a hatchback trunk in a vehicle. The vertical design will address the issue of limited space in the vehicle allowing for further storage of other needed items. The mechanical design of this toolbox will allow for an average daily drive to easily access the tools out from the depths of the trunk. In addition, the toolbox will address the issues of security, weight, and organization concerns; considering material to support the weight of the content of the tools, and providing easy access mounting the toolbox on a turntable to enable access and address limited space in the trunk.

INTERVIEWS

See Appendix A for more detailed and complete research on interviews.

CONCEPTS & INFORMATION

After doing research on several toolboxes for both small and large capacity hatchback trunks; there are several things to consider to meet the customer needs, wants, and to make the product unique. Some things to keep in mind about a toolbox and a mount for your vehicle are as follows:

PURPOSE

The purpose of this toolbox mount is to address the issue of limited space in the vehicle, provide easy accessible storage for tools to address any mechanical issues and or such things as roadside emergency issues. The toolbox mount allows you to place all tools into one central, organized spot while easily accessible without hurting your back to reach in and access your tools.

SECURITY

The security of your tools is essential, tools can be very costly and can draw unwanted attention to your vehicle. When you choose your toolbox to mount into the back of your vehicle be sure to select one with the ability to lock the drawers. This will address two things- one of which the security of your tools and the other to keep the drawers locked into place during transportation.

MATERIALS

1. Aluminum- Material that is often is used with a diamond shape pattern that is durable, and lightweight. This material is easy to work with and does not rust. Least costly of the three materials.
2. Steel- thicker gauge and heavier material, steel provides extreme durability, but needs to be coated to avoid corrosion. Moderate cost to use this material. The prime selection for holding the weight of the tools and the toolbox.
3. Stainless Steel- Of the three materials this is the costliest, however this material like aluminum does not rust, and has an eye appealing look to the material.

DIMENSIONS

Once you have selected the material, identified your purpose, and chosen your features, addressed your budget, you need to determine the dimensions of the toolbox. To expand the market for the toolbox, it will need to be adaptable and to determine the dimensions you will need to consider the sizes of several trunk spaces. The plate the toolbox will mount upon should be adaptable.

BUDGET

You will need to select the material, determine dimensions and features all while maintaining a low budget but high quality product that addresses the needs and wants of the customer. (1)

SOLUTION

The solution to developing a toolbox mount that reduces the space consumption in hatchback trunks while storing tools, in an organized manor, with security and easy access is; a low profile- toolbox mount that can mount upon a turntable within the bed of the vehicle.

A low profile toolbox mount allows the customer to take advantage of all the space within the trunk to mount the maximum size toolbox.

A turntable toolbox mount allows the customer to rotate the toolbox within the hatchback parallel with the mount to reduce square footage during travel and then to rotate the toolbox to easily access the content within.

A toolbox with the option to lock is a requirement in order to avoid drawers from opening during transportation.

CURRENT PRODUCTS

Figure 1: DeeZee Toolbox Example

Specialty Series Wheel Well Tool Box by Dee Zee®. Make the most of space that may be wasted on top of your pickup's rear wheel well humps with this series of tool boxes shaped to wrap on top of and around them. Crafted from a variety of durable materials, Dee Zee offers locking boxes that open from the top and boxes that open from the side to reveal sliding drawers. High-strength construction ensures they can take any hits from cargo in your box while remaining attractive and functional for years to come.

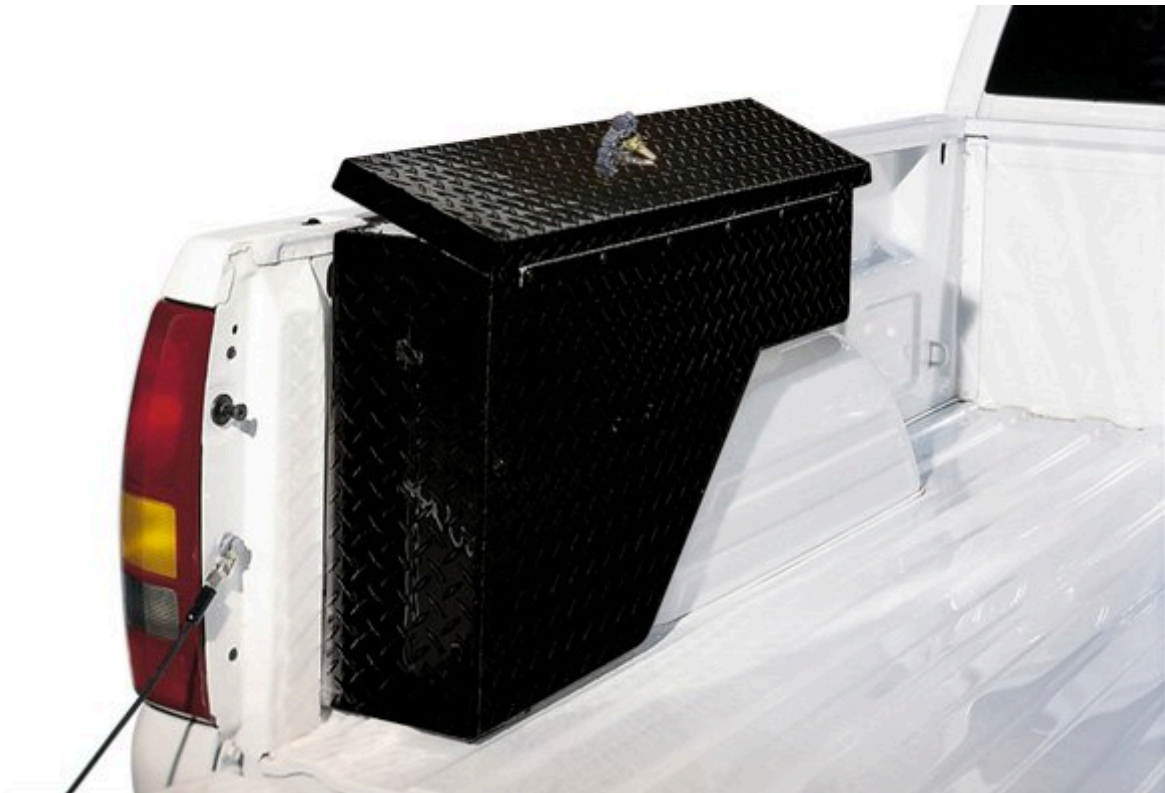

Features:

- Available in sizes that offer storage on top of and behind wheel well humps, or in double-wide size for storage on both sides of the wheel hump
- Versions are available with slide-out drawers
- Designed not to intrude any further into the center of your pickup bed than the wheel well humps already do
- Available in multiple finishes and colors
- Limited lifetime warranty on aluminum and polyurethane, 3-year warranty on steel, 1-year warranty on any powder coat finish
- Proudly manufactured in the United States

If you do not find yourself carrying 4 x 8 panels on top of your wheel wells, Dee Zee lets you use that space with a series of locking tool boxes designed to mount on top of and around wheel well humps – saving space in the front of your bed for other things. Whether you prefer lids that open from the top or from the side, you'll find a variety of styles to choose from. You'll find diamond tread aluminum construction, polyurethane plastic, and powder coated steel to match your preference. And if storage for smaller nut-and-bolt items is what you need, **Dee Zee** offers these boxes with slide-out drawers in a choice of materials and colors.

Metal wheel well boxes are finished with a protective layer of ceramic powder coat that is highly resistant to scratches, chips, and discolorations. High-strength polyurethane is available in black, and features reinforced framework that keeps the box rigid and sturdy enough to survive any hits from heavy cargo in your bed. Rubber gaskets effectively seal out moisture and the elements to keep what's inside dry. Dee Zee proudly manufactures all **Wheel Well Tool Boxes** in the United States and backs aluminum and polyurethane with a limited lifetime warranty, steel with a 3-year warranty, and applicable powder coat finish layers with a 1-year warranty.

CUSTOMER FEEDBACK AND OBJECTIVES

SURVEY ANALYSIS

Based off the survey information, the product objectives were created as a list of features to consider. Highlighted in **Red** is the average score for the following characteristics of importance based on the survey responses.

Ease of Use:

10	9	8	7	6	5	4	3	2	1	N/A
----	---	---	---	---	---	---	---	---	---	-----

Cost:

10	9	8	7	6	5	4	3	2	1	N/A
----	---	---	---	---	---	---	---	---	---	-----

Durability:

10	9	8	7	6	5	4	3	2	1	N/A
----	---	---	---	---	---	---	---	---	---	-----

Compact:

10	9	8	7	6	5	4	3	2	1	N/A
----	---	---	---	---	---	---	---	---	---	-----

Organization:

10	9	8	7	6	5	4	3	2	1	N/A
----	---	---	---	---	---	---	---	---	---	-----

Load Capacity:

10	9	8	7	6	5	4	3	2	1	N/A
----	---	---	---	---	---	---	---	---	---	-----

Safety:

10	9	8	7	6	5	4	3	2	1	N/A
----	---	---	---	---	---	---	---	---	---	-----

Maneuverability:

10	9	8	7	6	5	4	3	2	1	N/A
----	---	---	---	---	---	---	---	---	---	-----

Design/appearance:

10	9	8	7	6	5	4	3	2	1	N/A
----	---	---	---	---	---	---	---	---	---	-----

Adding Additional Features:

10	9	8	7	6	5	4	3	2	1	N/A
----	---	---	---	---	---	---	---	---	---	-----

CUSTOMER FEATURES
QUALITY FUNCTION DEPLOYMENT

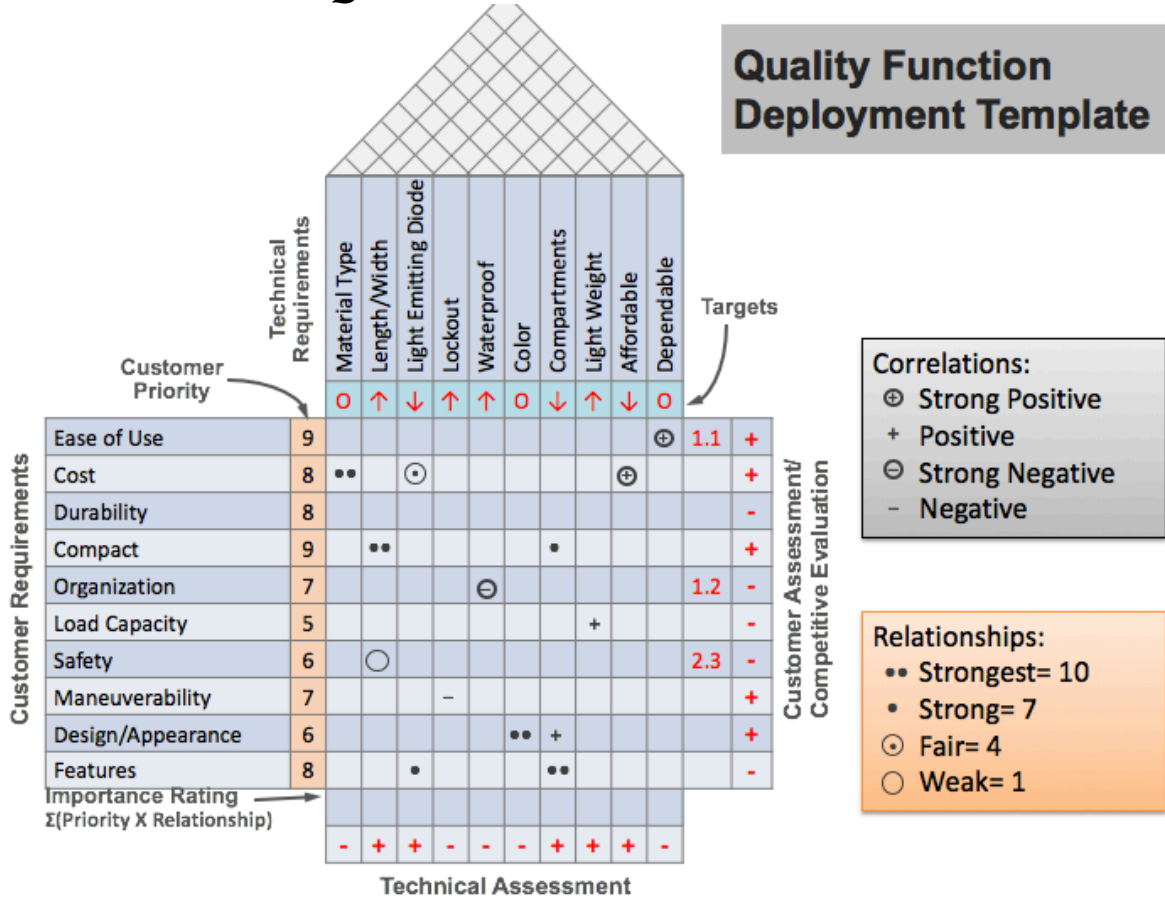

Table 1: Quality Function Deployment

DESIGN

MATERIALS/SPECIFICATIONS

1. Telescopic Slide
 - a. Stroke Length 315 mm
 - b. Dynamic Load Capacity 896 lbs.
 - c. Overall Height (A) 28 mm
 - d. Overall Width (B) 13 mm
 - e. Length (C) 610 mm
 - f. Mounting Holes (D)
 - i. Screw Size M5
 - ii. Depth 7.5 mm
 - iii. Number of Holes 8
 - g. Height (E) 15 mm
 - h. Mounting Holes (F)

- | | |
|---------------------|---------------|
| i. Screw Size | M5 |
| ii. Number of Holes | 8 |
| i. RoHS | Not Compliant |

“Allowing motion beyond your mounting surface, these slides are great for pick-and-place automated applications, machine tool doors, and telescopic industrial press arms. They function similarly to drawer slides, but they're more rugged and support heavier loads. Use them where tight tolerances are not required.”

“Slides are hardened zinc-plated steel with threaded through-holes. Ball bearings and rails are hardened steel. The rails accept flat head screws. Load capacities listed are for side mounting. If mounted horizontally or upside down, load capacity is 70% of the capacity listed. Not recommended for vertical mounting. Maximum temperature is 338° F.”

2. Corrosion-Resistant Turntable

- | | |
|---|----------|
| a. Load Capacity | 500 lbs. |
| b. Overall Size (A) | 6.06" |
| c. Center Diameter (B) | 4.68" |
| d. Top Center-to-Center (C) | 4.77" |
| e. Bottom Center-to-Center(C) | 5.56" |
| f. Hole Diameter | |
| i. (E) | 0.19" |
| ii. (F) | 0.094" |
| g. Number of Holes | 12 |
| h. Additional Specifications | |
| i. Square Turntables | |
| ii. Aluminum | |
| iii. Unlubricated | |
| iv. (E) dimension for bottom plate is 0.27". Top plate does not have (F) holes. | |

“Put a spin on your displays, industrial assemblies, and many other "lazy Susan" applications. All of these corrosion-resistant turntables have stamped plates and contain ball bearings that are housed in a large circular race. They also have a space-saving design that's only 5/16" high. Mounting fasteners not included. Lubricated turntables provide smoother, quieter motion.”

“Aluminum—Lightweight aluminum plates with stainless steel ball bearings.”

3. Strut Channel Accessory

- | | |
|--|--------------------------|
| a. 90 Degree Angle Bracket, 4-Hole, Type 304 Stainless Steel | |
| b. Material | Type 304 Stainless Steel |
| c. Length (A1), (A2) | 24.02” |
| d. Width (B) | 1.5” |
| e. Thickness | 0.25” |

- f. Screw Size 0.22"
- g. Number of Holes 4

Built thicker than other brackets for greater strength and durability. Mounting screws are not included.

4. "Gatehouse Ball Catch"

a. DIMENSIONS

- i. Center to Center Measurement (inches) 2
- ii. Product Height (in.) 2.125
- iii. Center to Center Measurement (mm) 51
- iv. Product Width (in.) 1
- v. Product Depth (in.) 1.438

b. DETAILS

- i. Builders Hardware Product Type Cabinet Latch
- ii. Latch type Surface mounted
- iii. Finish Brass
- iv. Material Metal
- v. Hardware Finish Family Brass

STRESS ANALYSIS & CALCULATIONS

Inner Shell

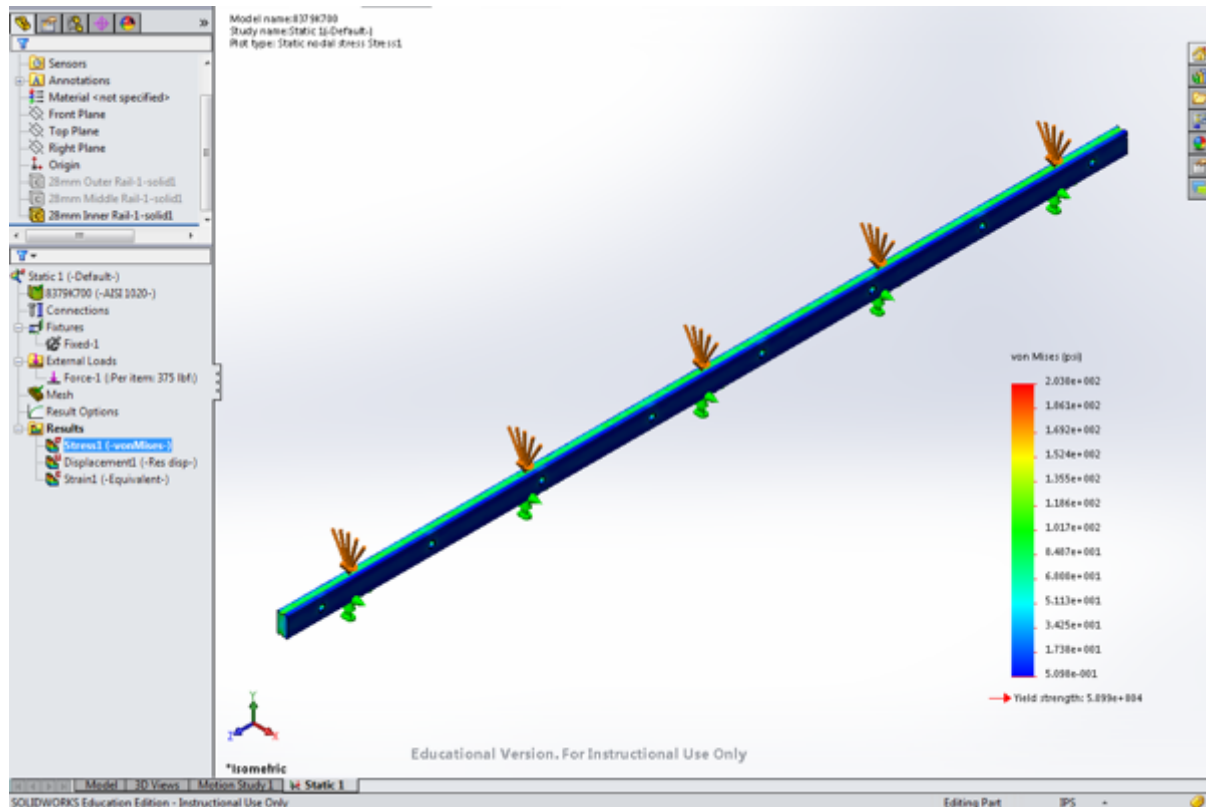

Figure 2: FEA Inner Shell

Material: AISI 1020 Steel
 Load Capacity: 375lbs
 Safety Factor: 1.5
 Yield Strength: 50,990lbs per square inch
 203 breaking point (highest stress) located in holes

Outer Shell

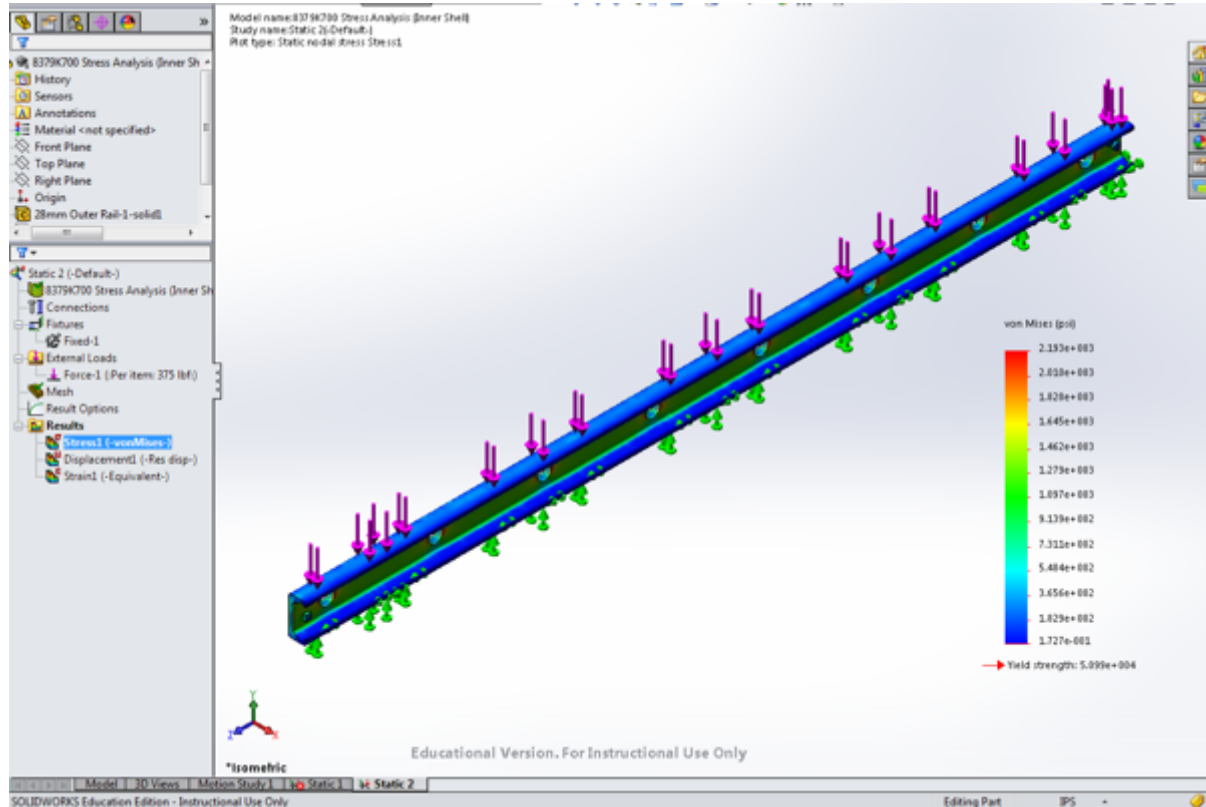

Figure 3: FEA Outer Shell

Material: AISI 1020 Steel
 Load Capacity: 375lbs
 Safety Factor: 1.5
 Yield Strength: 50,990lbs per square inch
 2193 breaking point (highest stress) located in holes

DRAWINGS

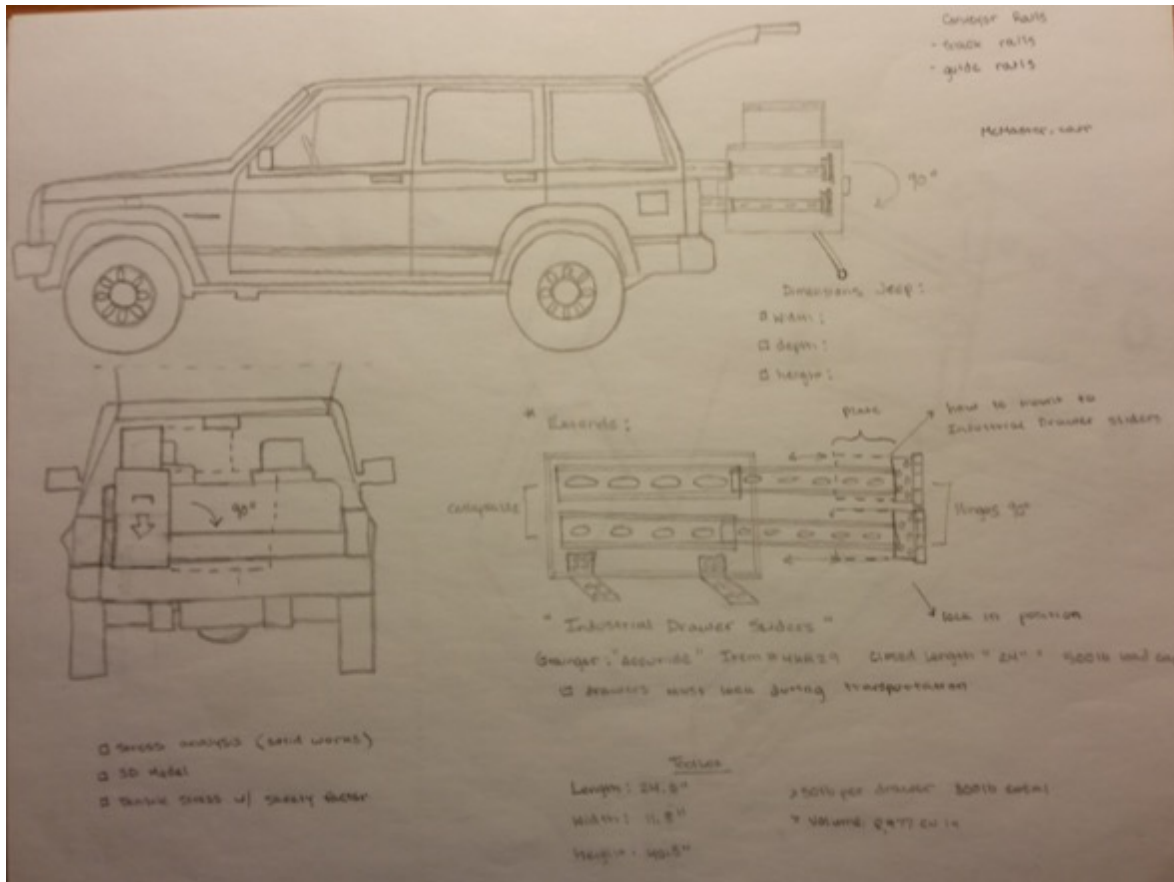

Figure 4: Sketch of Ideas/Concepts

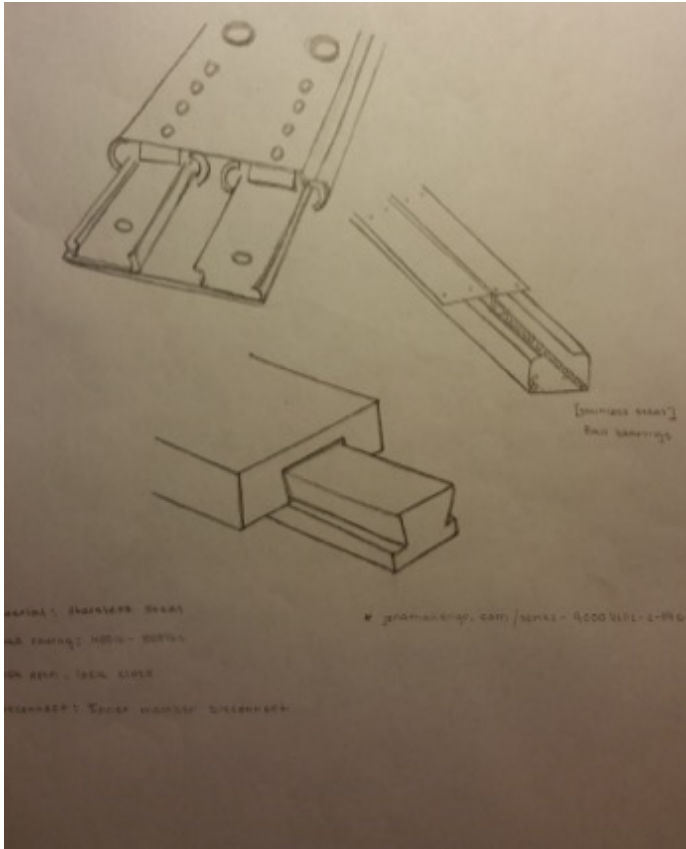
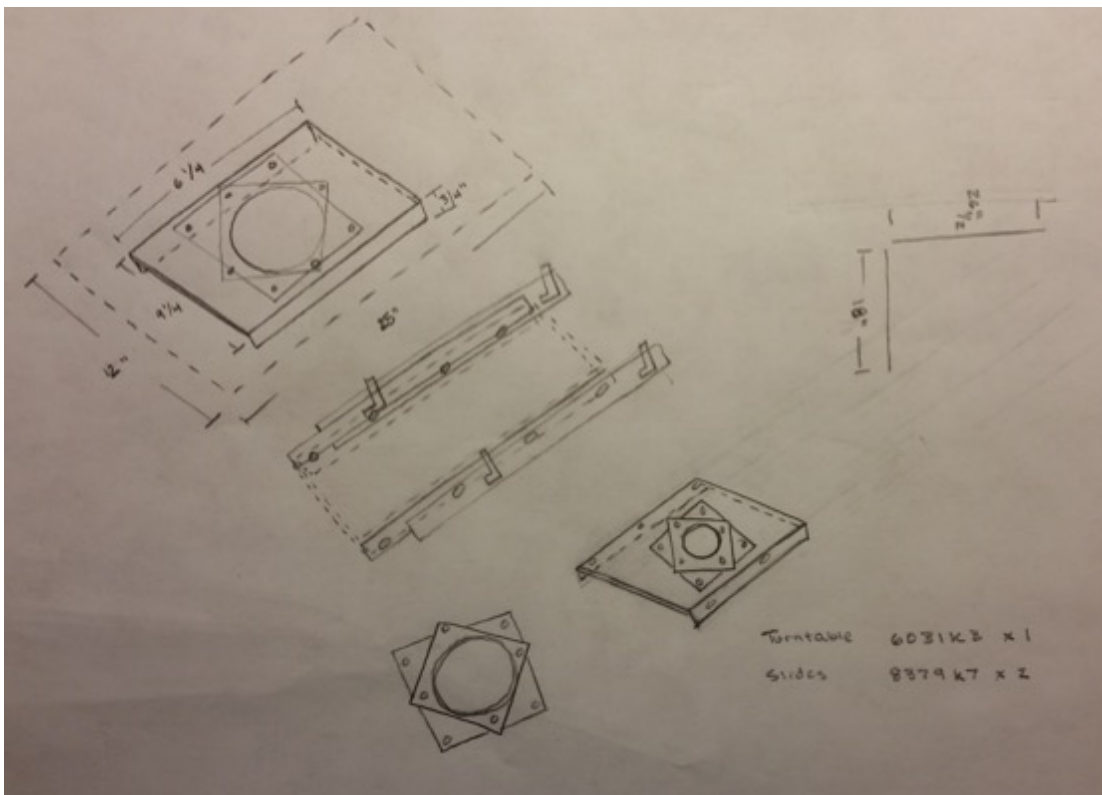

Figure 5: Sketch of Slider Concepts



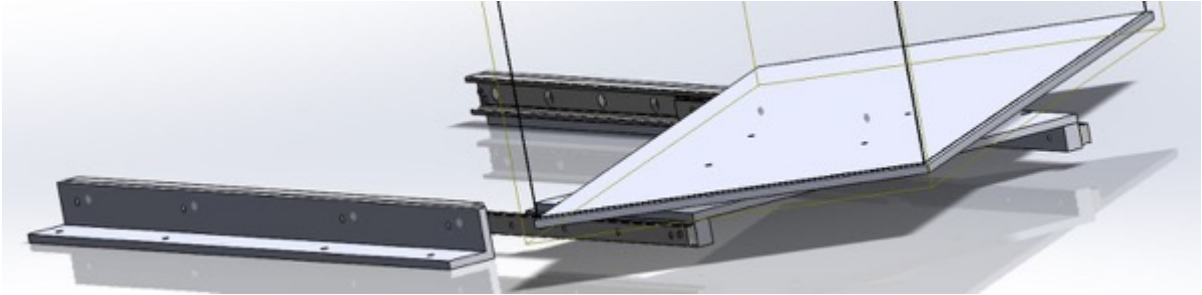

Figure 9: Design Concept (Side)



Figure 10: Design Concept (Front)

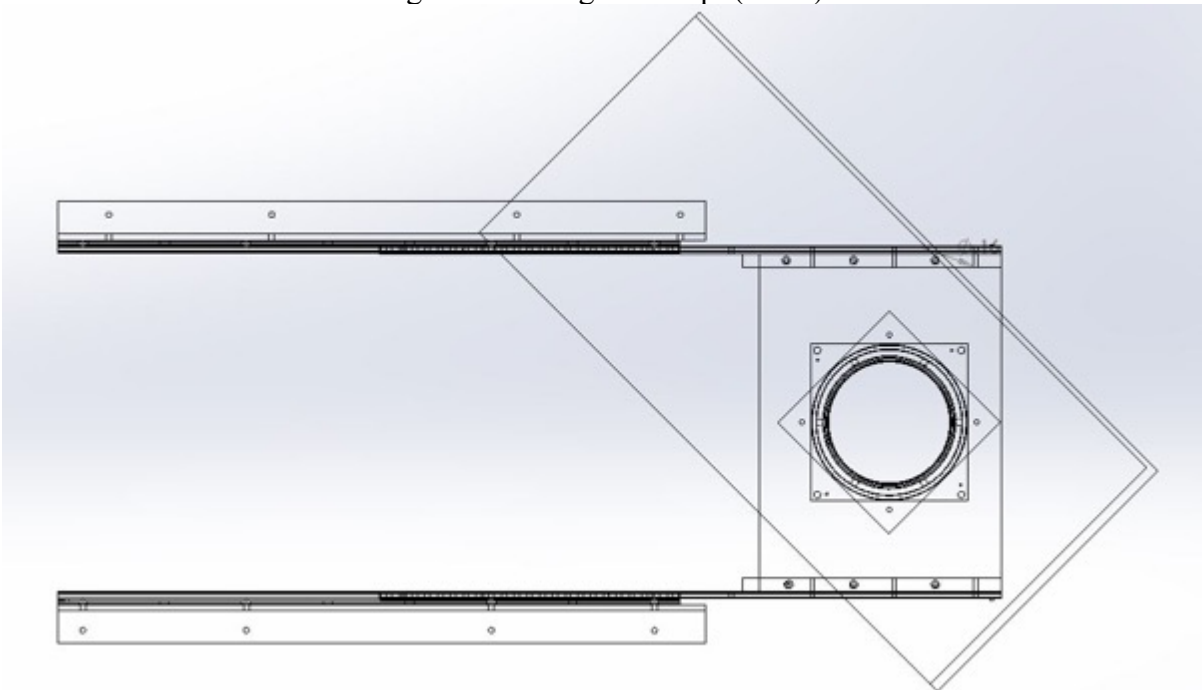

Figure 11: Design Concept (Top)

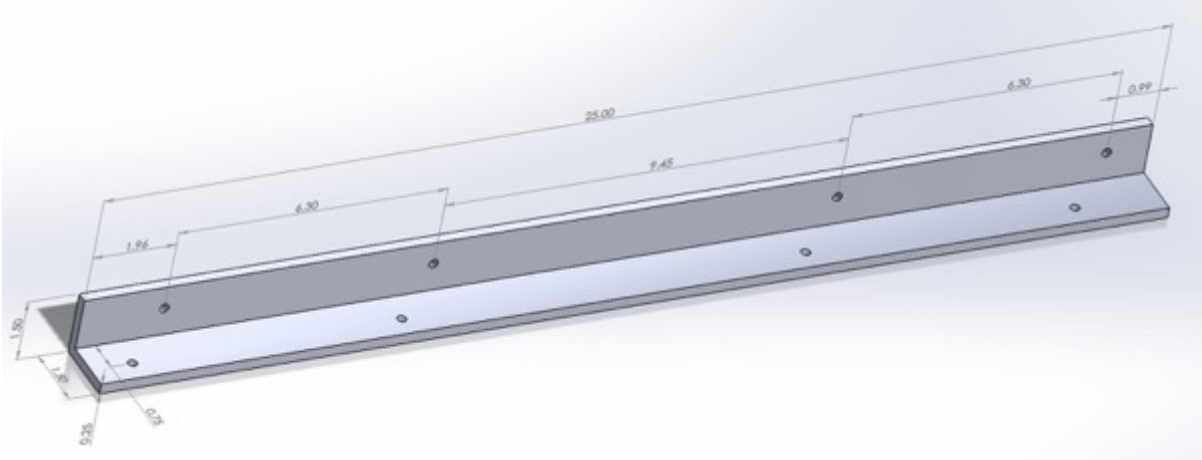

Figure 12: Design Concept (Mounting Angle)

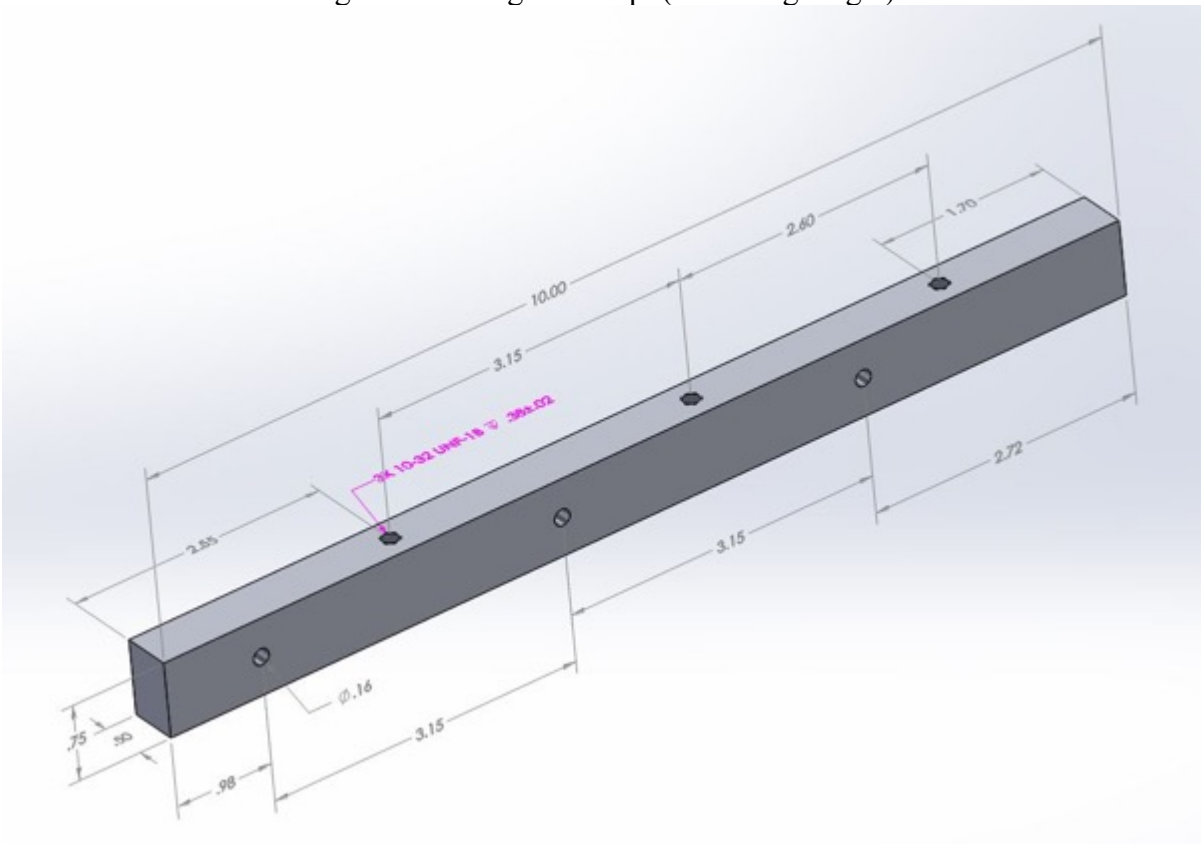

Figure 13: Design Concept (Mounting Bar)

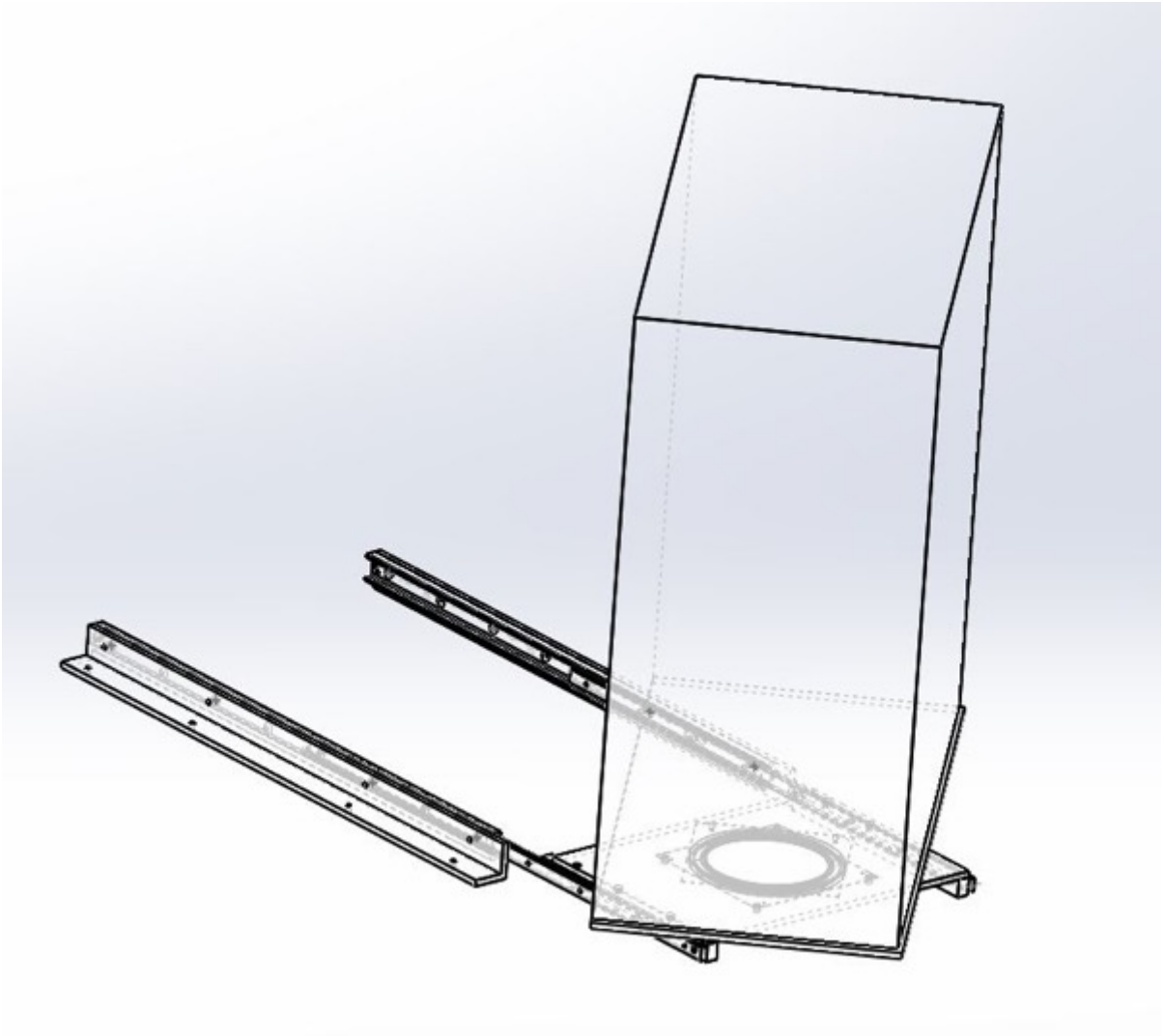

Figure 14: Design Concept (Isometric)

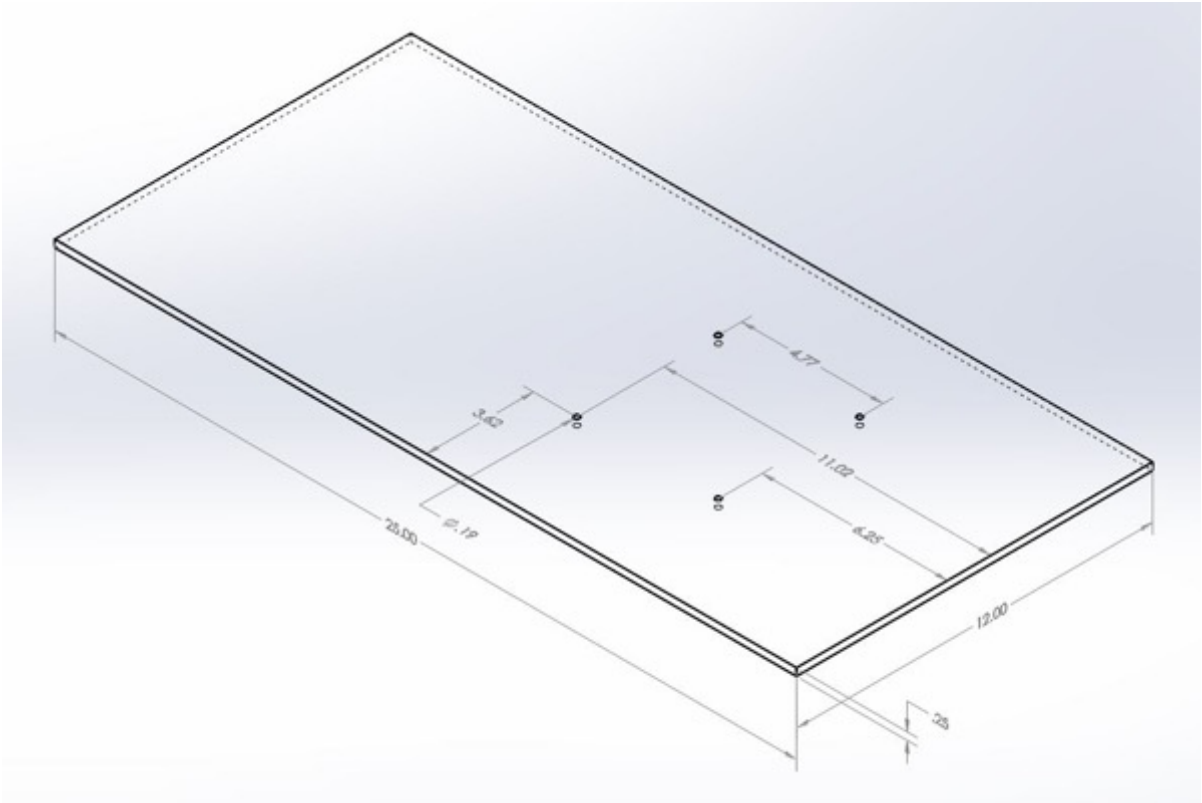

Figure 15: Design Concept (Toolbox Mounting Plate)

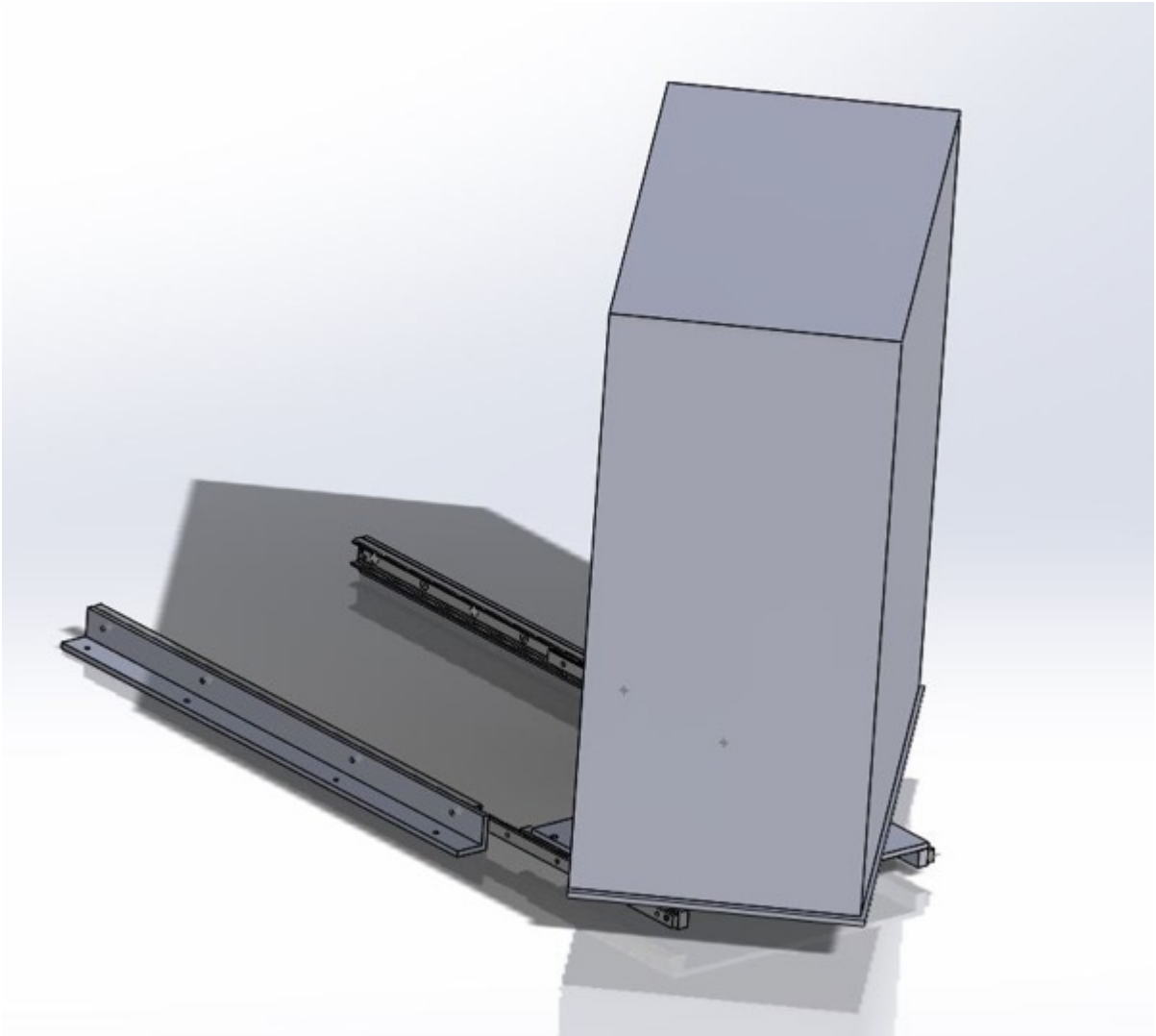

Figure 16: Design Concept (Isometric Dark)

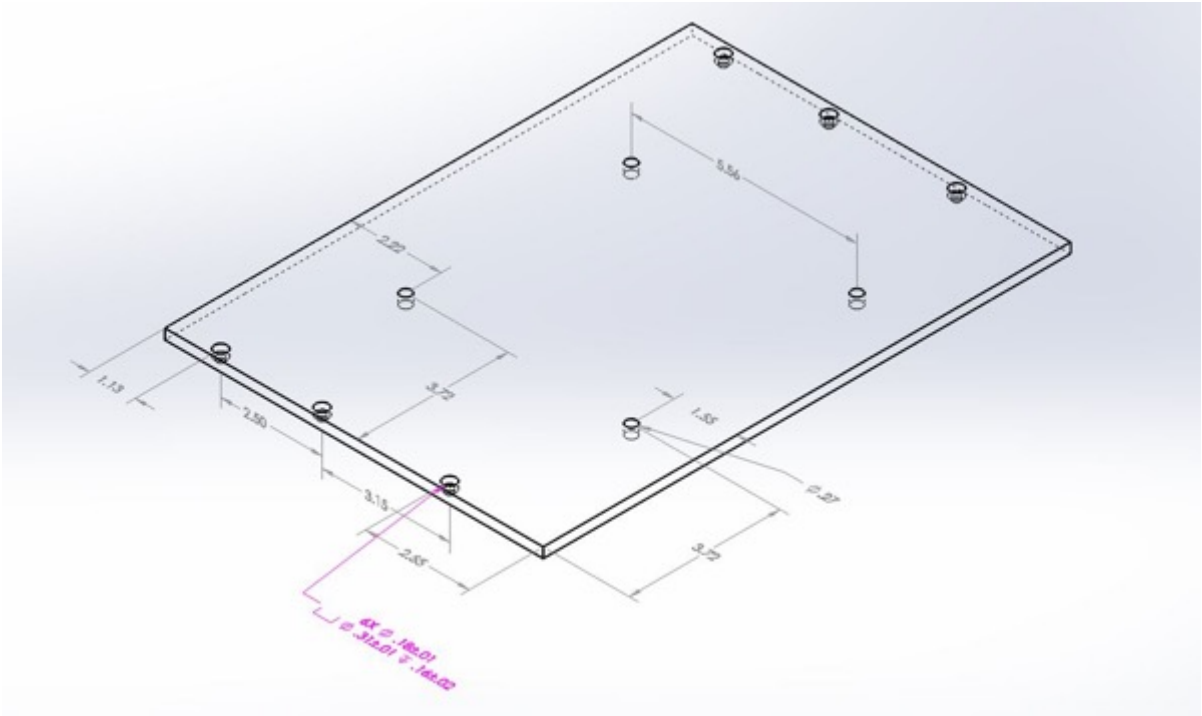

Figure 17: Design Concept (Turntable Mounting Plate)

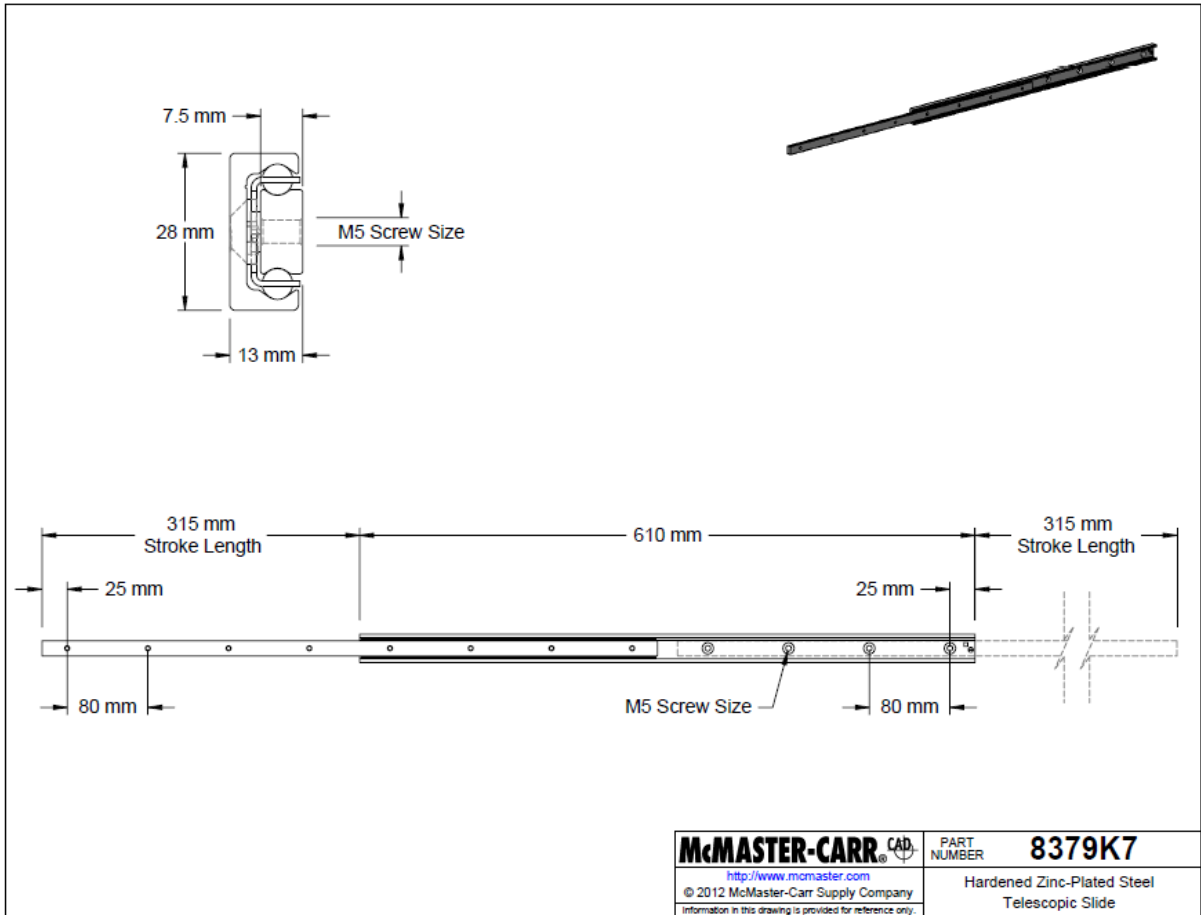

Figure 18: Telescopic Slide Drawings

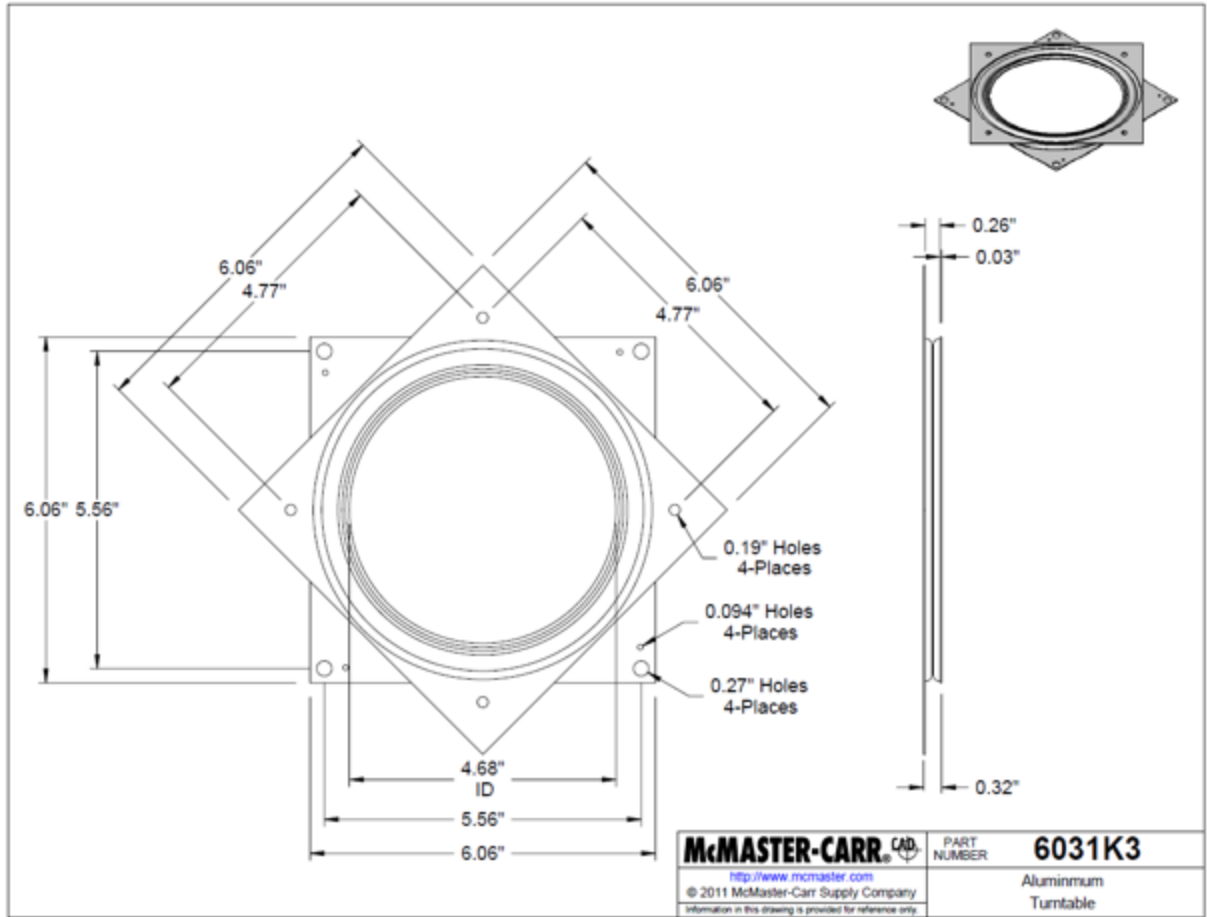

Figure 19: Turntable Drawings



Figure 20: Ball Door Stop

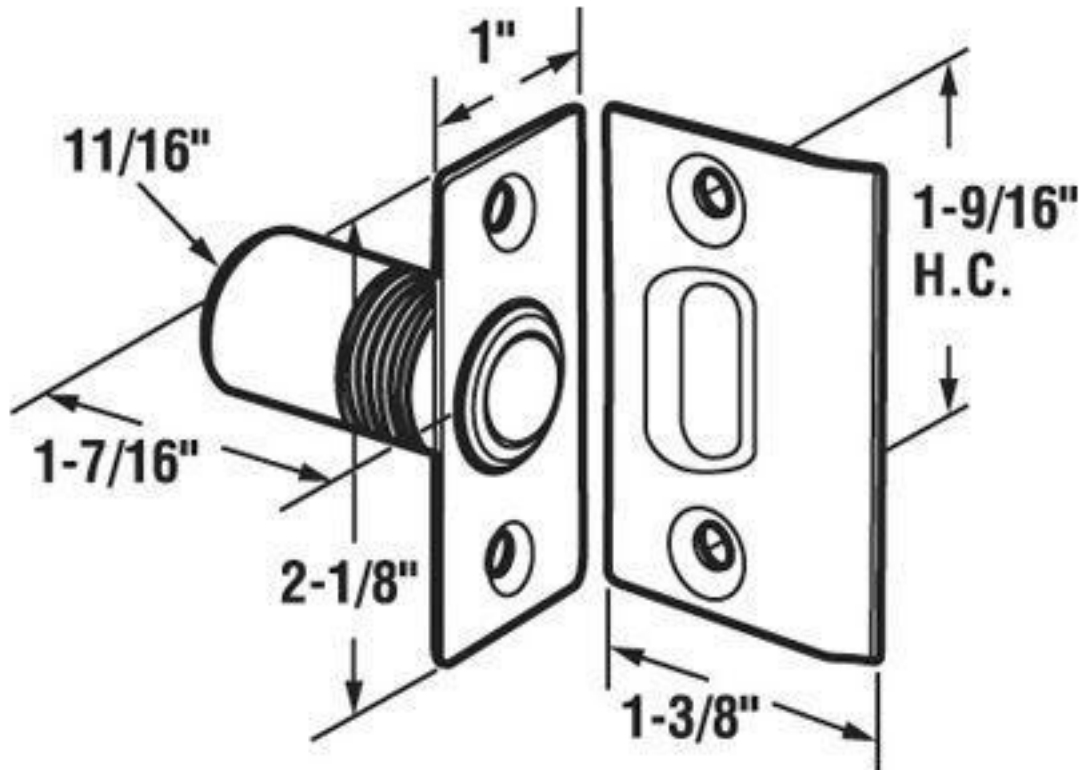

Figure 21: Ball Door Stop Drawing

SCHEDULE & BUDGET

Schedule:

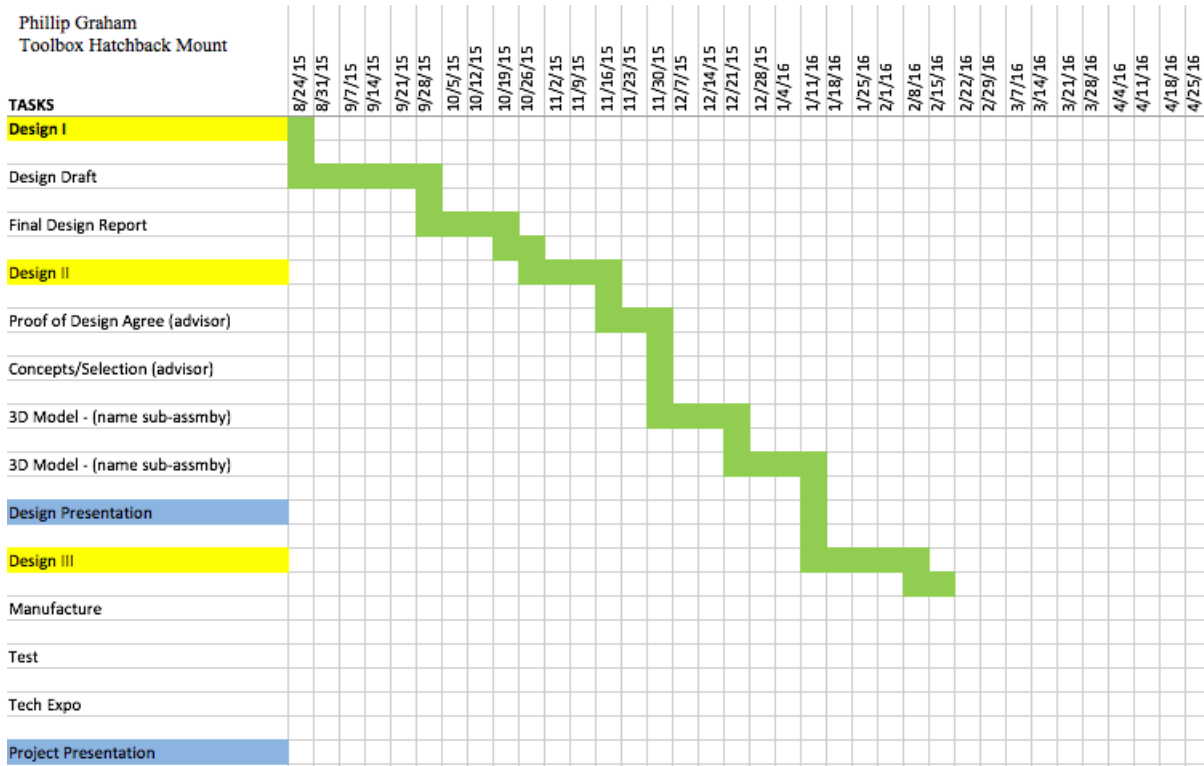

Table 2: Schedule

Budget: \$450

Products						Show line references
Purchase order (optional)						
Line	Quantity	Product		Ships	Unit price	Total
1	<input type="text" value="2"/>	8379K7	Telescopic Slide, 315 mm Stroke Length, 896 lb Load Capacity	in the morning	\$188.36 each	376.72
	each					
2	<input type="text" value="1"/>	6031K3	Corrosion-Resistant Turntable, Aluminum, 6.06" Square	in the morning	29.49 each	29.49
	each					
3	<input type="text"/>	<input type="text"/>				
<input type="button" value="ADD"/> <input type="button" value="1"/> Paste products and quantities						Merchandise total \$406.21
Special instructions						
<input type="button" value="PLACE ORDER"/>						

FABRICATION & TESTING

CUT LIST:

1. (2) 1 1/2" x 1 1/2" x 1/4" angle x 25" LG.
2. (2) 1/2" x 3/4" x 10" LG. CRS
3. (1) 1/4" x 10" x 13" LG. Plate
4. (1) 1/4" x 12" x 25" LG. Plate

TOOLING:

- Drill Bit Sizes: Size 7, 21, 19, 9/32

- ¼” -20 Tap thru (4) places-typ

CONCLUSION/RECOMMENDATIONS

The hatchback toolbox mount was built and designed with the knowledge that improvements and changes will follow. Like any engineer we always seek to improve, alter, and evaluate designs.

1. Turntable
 - a. Option 1- Develop and design the turntable to mount within the center of the turntable plate.
 - b. Option 2- Research and purchase a heavier and more durable turntable with a thicker supporting plate to maintain a level toolbox throughout operation.
2. Sliders
 - a. Option 1- Incorporate a locking mechanism to enable the sliders to lock within place in full extension and full collapsed position.
 - b. Option 2- Research and purchase a set of sliders that enable locking positions that will allow access after the toolbox is mounted.
3. Toolbox Mounting Plate
 - a. Option 1- Develop and design and research popular toolbox dimensions and incorporate easily mountable slots for the toolbox to mount to the plate.
 - b. Option 2- Develop and design a grip to expand and retract with a specific tension around the toolbox to easily mount to toolbox to the plate.
 - i. Both options allow for other models to be mounted therefor increasing the population of interest.
4. Mounting Angles
 - a. Option 1- Develop and design a universal mounting plate for the bed of the trunk to increase and reinforce the angles to the bed.

Extra

I decided to incorporate a ball catch on the underside of the turntable mounting plate and up through to the toolbox mounting plate with a pocket for the ball to catch.

This will address two concerns- one of which the ball catch will top the toolbox from rotating when rotated after full extension perpendicular with the mount and will catch when collapsing the toolbox parallel with the mount.

WORKS CITED

1. Autoanything.com, 2015, What Are The Best Truck Toolboxes? How Truck Toolboxes Work - Style Benefits & Install Tips. [online]. 2015. [Accessed 9 October 2015]. Available from: <http://www.autoanything.com/truck-toolboxes/50A33A177A1.aspx>
2. CARiD.com, 2015, Dee Zee® - Specialty Series Wheel Well Tool Box. [online]. 2015. [Accessed 9 October 2015]. Available from: <http://www.carid.com/dee-zee/wheel-well-tool-box.html#product-details-tab>

3. profile, View, 2015, Truck Tool Box: The Benefits Of Using Aluminum Truck Tool Boxes. *Trucktoolbox15.blogspot.com* [online]. 2015. [Accessed 9 October 2015]. Available from: <http://trucktoolbox15.blogspot.com/2015/04/the-benefits-of-using-aluminum-truck.html>

APPENDIX A

Interview: Cory Franklin
Profession: Electrical Engineering/Project Management
Date: October 2nd 2015

Ease of Use:

10 9 8 **7** 6 5 4 3 2 1 N/A

Cost:

10 9 8 7 **6** 5 4 3 2 1 N/A

Durability:

10 9 **8** 7 6 5 4 3 2 1 N/A

Compact:

10 9 **8** 7 6 5 4 3 2 1 N/A

Organization:

10 9 8 7 **6** 5 4 3 2 1 N/A

Load Capacity:

10 9 8 7 6 5 **4** 3 2 1 N/A

Safety:

10 9 8 7 6 5 **4** 3 2 1 N/A

Maneuverability:

10 9 8 7 **6** 5 4 3 2 1 N/A

Design/appearance:

10 9 8 7 6 5 4 **3** 2 1 N/A

Adding Additional Features:

10 9 8 7 **6** 5 4 3 2 1 N/A

Any Addition comments, suggestions and ideas are welcome below:

1. This sounds like a great senior project, my feelings on this would be that it should be able to hold your important tools.
2. It would be nice to be able to easily access these tools in an emergency.
3. As for the additional features it would be nice to stay organized and easily moveable.
4. Design doesn't impact me much as a potential customer. Hopefully these thoughts will help in the design.

Interview: Mike Karaglanis
Profession: Mechanical Engineering/Project Management
Date: October 2nd 2015

Ease of Use:

10	9	8	7	6	5	4	3	2	1	N/A
Cost:										
10	9	8	7	6	5	4	3	2	1	N/A
Durability:										
10	9	8	7	6	5	4	3	2	1	N/A
Compact:										
10	9	8	7	6	5	4	3	2	1	N/A
Organization:										
10	9	8	7	6	5	4	3	2	1	N/A
Load Capacity:										
10	9	8	7	6	5	4	3	2	1	N/A
Safety:										
10	9	8	7	6	5	4	3	2	1	N/A
Maneuverability:										
10	9	8	7	6	5	4	3	2	1	N/A
Design/appearance:										
10	9	8	7	6	5	4	3	2	1	N/A
Adding Additional Features:										
10	9	8	7	6	5	4	3	2	1	N/A

Any Addition comments, suggestions and ideas are welcome below:

1. Is this an integrated tool box that is re-movable from the vehicle?
2. I'm thinking if it is a true, handyman or field worker that the tool box needs to be removable.
3. What types of tools are in the base package? Are there different packages based on primary function?
4. Would tools to work on the vehicle be included - for maintenance or emergency?
5. If tools are included for a vehicle emergency - it would be nice if there was a ref for usage in the vehicle maintenance manual describing which tool for which application/usage...especially for the novice.

